

e-BID NOTICE

Bid No. 1351(27)/NIFT/Pur-HO/INDIAsize Project/ Scan Suit/2020

**e-BID DOCUMENT
FOR
Scan Suit for INDIAsize**



NATIONAL INSTITUTE OF FASHION TECHNOLOGY

(A statutory body governed by the NIFT Act 2006 and
Set up by the Ministry of Textiles, Govt. of India)

NIFT CAMPUS, NEAR GULMOHAR PARK, HAUZ KHAS,
NEW DELHI – 110016
PHONE: (011) 26542071/2176, EMAIL ID- purchase.ho@nift.ac.in
Website: www.nift.ac.in

Notice Inviting E-Tender

Online bids under **Two Bid** system (**viz. Technical Bid and Financial Bid**) along with samples are invited by the NIFT – Head Office, Hauz Khas, New Delhi from bonafide, experienced and *reputed Company (Pvt. Ltd. Company/Partnership firm/ LLP/ Proprietorship firms)/ Manufacturer/ Authorized Dealer/ Agent/ Retailer/ Vendor/ Distributor for providing Scan Suits for the INDIAsize Project.*

Table – I: NIT & Eligibility Criteria Document Details.

SI.No.	Description	Details
1.	NIT NO.	Bid No. 1351(27)/NIFT/Pur-HO/INDIAsize Project/ Scan Suit/2020 Dated 21.10.2020
2.	Earnest Money Deposit (EMD) Ref Clause 4.2	<p>The bidder shall furnish the EMD/Bid security of Rs. 9 lakhs in one of the following ways: -</p> <p>(a) In form of Demand Draft of any Indian Nationalized/ Scheduled Bank in favour of NIFT, Head Office, Hauz Khas, New Delhi payable at Delhi. Or</p> <p>(b) Bank Guarantee from any Indian Nationalized/ Scheduled Bank in favour of “NIFT, Head Office, payable at Delhi” shall be valid for minimum 180 days from the tender opening date. Or</p> <p>(c) Bank Transfer in NIFT’s Account: Account Name: INDIASIZE PROJECT Account Number: 340602050000038 IFSC Code: UBIN0534064</p> <p>EMD in a sealed envelope/ Proof of Payment in NIFT’s Account has to be submitted to Purchase Officer, NIFT, Head Office, Hauz Khas, New Delhi–110016 before 14:00hrs of 17.11.2020 otherwise the Bid shall not be considered.</p>
3.	Availability of Tender Document	<p>i. A complete set of Bidding Document in English may be downloaded at free of cost from CPP Portal (URL: https://nifttenders.eproc.in) and NIFT, website (URL: https://www.nift.ac.in). Corrigendum/addendum, if any, shall be published only on the website and separate communication will not be sent for the same.</p>

		<p>ii. Instructions regarding submission of online bids are available at URL: https://nifttenders.eproc.in</p> <p>iii. Bids shall be submitted through online mode only. Manual / physical bids will not be accepted.</p> <p>iv. On submission of online bid, please intimate the same to the e-mail ID: purchase.ho@nift.ac.in</p>
4.	Date of Publication of Bid notification on official website/e-Portal	21.10.2020 at 1700 Hours (IST)
5.	Download of Bid Document Commence from	21.10.2020 at 1800 Hours (IST)
6.	Pre-Bid Meeting	02.11.2020 at 1100 Hours (IST)
7.	Amendment of bid document	12.11.2020 at 1100 Hours (IST)
8.	Last Date of download of Bid Document	17.11.2020 at 1200 Hours (IST)
9.	Last Date for submission of duly filled in Bids	17.11.2020 at 1500 Hours (IST)
10.	Place of opening of Tender bids	Online or Board Room, NIFT – Head Office, Hauz Khas, New Delhi – 110016
11.	Date and Time of the opening Technical Bids	17.11.2020 at 1600 Hours (IST)
12.	Date and Time of the opening Price Bids	Will be notified to the technically qualified Bidders
13.	Eligibility Criteria	<p>The Bidder must have following documents for ELIGIBILITY CRITERIA</p> <p>A. Proof of Registration B. Taxpayer Information C. Turnover Certification & Income Tax Return D. Bidders Experience Certificate E. Earnest Money Deposit F. Tender Acceptance letter G. Price Bid H. Samples</p>
14.	Rejection of Tender	Incomplete, ambiguous and conditional rate, late receipt of tender shall be rejected.

NOTE:

- i) NIFT has decided to use the process of e-tendering for inviting this tender and thus the physical copy of the tender would not be sold.
- ii) Incomplete, ambiguous and conditional tender bids liable to be rejected.
- iii) Amendments, if any, to the tender document, will be notified on the above website as and when such amendments are undertaken particularly before **2200 Hours of 12.11.2020**. It is the responsibility of the Bidders who have downloaded the tender document from the website to keep themselves abreast of such amendments before submitting the tender document.
- iv) Intending Bidders are requested to register themselves with <https://nifttenders.eproc.in> through www.nift.ac.in/tender for obtaining user-id, Digital Signature etc. by paying Vendor registration fee and processing fee for participating in the above mentioned tender.
- v) The Bidder shall furnish a declaration under their digital signature that no addition/ deletion/corrections have been made in the downloaded tender document being submitted and it is identical to the tender document appearing on the website (www.nift.ac.in/tender).
- vi) In case of any correction / addition / alteration / commission in the tender document, the tender bid shall be rejected summarily.
- vii) All statutory taxes as applicable shall be deducted at source before payment.
- viii) The Bidder should refer to Clause 6.3 of this document for details of documents to be scanned and uploaded in the NIFT portal.
- ix) NIFT reserves the right to amend or withdraw any of the terms and conditions contained in the tender document or to reject any or all the tenders in whole or in part without giving any notice or assigning any reason thereof or is not bound to accept the lowest tender.

Contents

1. PART I- BACKGROUND ABOUT NATIONAL SIZING SURVEY OF INDIA	6
1.1 SPECIFIC OBJECTIVES & SCOPE	6
1.2 PROJECT ENTAILS	6
1.3 GEOGRAPHICAL COVERAGE	7
1.4 REGION WISE SCAN SUIT REQUIREMENT	7
1.4.1 SCAN SUIT REQUIREMENT- REGION WISE DISTRIBUTION	7
1.4.2 SCAN SUIT REQUIREMENT- STATE WISE DISTRIBUTION OF SIZES	8
1.5 TIME PERIOD OF THE CONTRACT	8
2. PART II - PURPOSE OF THE BID	9
2.1. RECRUITMENT OF BIDDER	9
2.2. SCOPE OF WORK OF BIDDER	9
2.2.1 TECH PACKS	10
2.2.2 DELIVERY AND TRANSPORTATION OF THE SCAN SUITS	25
2.2.3 SAMPLES TO BE SUBMITTED WITH THE TECHNICAL BID	26
2.2.4 INSPECTION AUTHORITY	26
2.3. ROLE AND RESPONSIBILITY OF BIDDER	27
2.3.1 COMPENSATION	27
2.3.1.1 Workmen's Compensation	27
2.3.1.2 Labour Welfare	27
2.3.1.3 Fair Wages	28
2.3.1.4 Other Consideration of Bidder	28
3. PART III- GUIDELINES FOR SUBMITTING THE BID	30
3.1. INFORMATION ON BID	30
3.2. PREPARATION OF THE BID	30
3.3. PROCESS OF ONLINE REGISTRATION	30
3.4. ONLINE SUBMISSION OF BID	31
4. PART IV - PAYMENT TERMS	33
4.1. PAYMENT SCHEDULE	33
4.2. EARNEST MONEY DEPOSIT	34
4.3. PERFORMANCE BANK GUARANTEE (PBG)	34
5. PART V - GENERAL TERMS AND CONDITIONS	35
5.1. LANGUAGE OF BID	35
5.2. CLARIFICATION ON BIDDING DOCUMENTS	35
5.3. AMENDMENT OF BIDDING DOCUMENTS	35
5.4. MODIFICATION/ SUBSTITUTION/ WITHDRAWAL OF BIDS	35

5.5.	REJECTION OF BID	35
5.6.	RIGHT TO ACCEPT ANY BID AND TO REJECT ANY OR ALL BIDS	36
5.7.	NONCONFORMITIES, ERRORS AND OMISSIONS	36
5.8.	CONTACTING THE NIFT	36
5.9.	BIDS OF DEBARRED/ BLACKLISTED FIRMS	36
5.10.	PRE-BID MEETING	36
5.11.	TECHNICAL BID OPENING	36
5.12.	PLACE OF OPENING OF BID	37
5.13.	TIME AND DATE FOR OPENING OF TECHNICAL BIDS	37
5.14.	OPENING OF PRICE BID	37
5.15.	PERIOD OF VALIDITY OF BIDS	37
5.16.	ISSUE OF LETTER OF INTENT (LOI)	38
5.17.	PENALTY FOR USE OF UNDUE INFLUENCE	38
5.18.	ACCESS TO BOOKS OF ACCOUNTS	38
5.19.	NON-DISCLOSURE OF CONTRACT DOCUMENTS	39
5.20.	CONTRACT AMENDMENTS	39
5.21.	TRANSFER AND SUB-LETTING	39
5.22.	WITHHOLDING OF PAYMENT	39
5.23.	LIQUIDATED DAMAGES	39
5.24.	TERMINATION FOR DEFAULT	39
5.25.	TERMINATION FOR INSOLVENCY	40
5.26.	FORCE MAJEURE	40
5.27.	SETTLEMENT OF DISPUTES THROUGH ARBITRATION	40
5.28.	COURT JURISDICTION	41
5.29.	NOTICES	41
5.30.	TAXES AND DUTIES	41
5.31.	DELIVERY	41
5.32.	PENALTY FOR SUBSTANDARD / INFERIOR QUALITY	42
5.33.	CHANGE IN QUANTITY	42
5.34.	AWARD OF CONTRACT	42
6. PART VI - ELIGIBILITY CRITERIA FOR BID EVALUATION		43
6.1.	BID SYSTEM & EVALUATION	43
6.2.	THE BID EVALUATION PROCESS	43
6.3.	TECHNICAL BID EVALUATION	43
6.4.	TECHNICAL BID EVALUATION	45
6.5.	PRICE BID	46
6.6.	PRICE BID EVALUATION	47
ANNEXURE I - TECHNICAL BID		48
ANNEXURE II - DETAILS OF EARNEST MONEY DEPOSIT		51
ANNEXURE III - PRICE BID		52
ANNEXURE IV – TENDER ACCEPTANCE LETTER		53

1. PART I- BACKGROUND ABOUT NATIONAL SIZING SURVEY OF INDIA

National Institute of Fashion Technology (NIFT)

NIFT was set up by the Ministry of Textiles, Government of India in 1986 which has been accorded statutory status under the Act of Parliament in 2006 (NIFT Act 2006) for the promotion and development of education and research in the field of Fashion Technology. NIFT provides fashion business education across the country through its network of 16 campuses. It provides four years undergraduate (UG) program in design and technology, two years post graduate (PG) program in design, fashion management & fashion technology and short duration education program to address the specialized needs of professionals and students in the field of fashion. NIFT has its Head Office at New Delhi with its campuses located at Bengaluru, Bhopal, Bhubaneswar, Chennai, Delhi, Gandhinagar, Hyderabad, Jodhpur, Kangra, Kannur, Kolkata, Mumbai, Patna, Raebareli, Shillong and Srinagar.

National Sizing Survey of India called INDIAsize

NIFT, New Delhi under the aegis of the Ministry of Textiles, Govt. of India, is undertaking an extensive research study to develop a comprehensive size chart for ready to wear industry based on these body measurements of the Indian population. This is a scientific exercise where anthropometric data will be collected from a sample population to create a database of measurements that will culminate in a standardized size chart truly representative of the Indian population, which can be adopted by the entire apparel Industry.

1.1 Specific Objectives & Scope

The main objective of the INDIAsize project is to identify the body dimensions and proportions of India females and males using 3D body scanning technology and develop a size chart based on body measurements of Indian population for better fitting of ready to wear garments. The INDIAsize project will also focus on collection of demographics through using of socio-demographic questionnaires.

1.2 Project Entails

The project approved by Government of India entails measuring approximately 25000 (Twenty Five Thousand) male and female persons between the age group of 15 years and 65 years above in six different cities located in six regions of India i.e. Kolkata (East), Mumbai (West), New Delhi (North), Hyderabad (Centre), Chennai (South), and Shillong (North-East) using 3D whole body scanners. The participants in the study need to wear a scan suit before getting scanned. The Bidder has to supply scan suit sets for the same.

1.3 Geographical Coverage

The purpose of INDIAsize project is to collect a large set of anthropometric data representative of the overall Indian population. Therefore, to collect this pan India data the 3D body scanners will be positioned at different locations in six geographical regions of India.

S. No.	Geographical Region	City	Time duration
1	North	New Delhi	3 months
2	West	Mumbai	3 months
3	South	Chennai	3 months
4	Centre	Hyderabad	1.5 months
5	East	Kolkata	3 months
6	North-East	Shillong	2 months

1.4 Region Wise Scan Suit Requirement

Total requirement of the scan suit is 30000 sets.

1.4.1 Scan Suit Requirement- Region Wise Distribution

Geographic al Region No.	Geographical Region	No. of Samples of which 50% are male and 50% female	Delivery amount and location	Delivery date
1	North India (New Delhi)	7500	1st lot - 50% 15000 scan suits and 2500 brassieres delivered to NIFT Delhi	2.5 months after placing the order
2	West India (Mumbai)	7500		
3	South India (Chennai)	3750	2nd lot-25% 7500 scan suits and 1250 brassieres delivered to NIFT Chennai	After 5.5 months of first delivery
4	Central India (Hyderabad)	3750		
5	East India (Kolkata)	3750	3rd lot -25% 7500 scan suits and 1250 brassieres delivered to NIFT Kolkata	After 4 months of second delivery
6	North-East India (Shillong)	3750		
	Total	30000		

1.4.2 Scan Suit Requirement- State Wise Distribution of Sizes

Total Quantity of scan suits - Size wise ratio									
SIZE SET	XXS	XS	S	M	L	XL	XXL	XXXL	TOTAL
Number of sets for males	900	1900	2800	3500	2800	1900	800	400	15000
Number of sets for females	900	1900	2800	3500	2800	1900	800	400	15000

First order to be 50% of the total order to be delivered to NIFT Delhi for Delhi and Mumbai
Address NIFT Balbir Saxena Marg, Near Gulmohar Park, Hauz Khas, New Delhi, Delhi 110016

SIZE SET	XXS	XS	S	M	L	XL	XXL	XXXL	TOTAL
Number of sets for males	450	950	1400	1750	1400	950	400	200	7500
Number of sets for females	450	950	1400	1750	1400	950	400	200	7500

Second order to be 25% to be delivered to NIFT Chennai after 5.5 months of the first delivery for
Chennai and Hyderabad

Tentative size ratio below Size wise ratio may change following data collection in Delhi and Mumbai
Final ratio will be advised 1.5 months before the delivery date

Address: NIFT Campus, Rajiv Gandhi Salai Taramani, CHENNAI - 600 113

SIZE SET	XXS	XS	S	M	L	XL	XXL	XXXL	TOTAL
Number of sets for males	225	475	700	875	700	475	200	100	3750
Number of sets for females	225	475	700	875	700	475	200	100	3750

Third order to be 25% to be delivered to NIFT Kolkata after 4 months of the second delivery for
Kolkata and Shillong

Tentative size ratio below Size wise ratio may change following data collection in Delhi, Mumbai,
Chennai and Hyderabad

Final ratio will be advised 1.5 months before the delivery date

Address: NIFT Plot, 3B, LA Block, Sector III, Bidhannagar, Kolkata, West Bengal 700098

SIZE SET	XXS	XS	S	M	L	XL	XXL	XXXL	TOTAL
Number of sets for males	225	475	700	875	700	475	200	100	3750
Number of sets for females	225	475	700	875	700	475	200	100	3750

1.5 Time Period of the Contract

The overall duration of the contract is about 13 months and it starts from signing of the contract/ agreement with NIFT till submission of the Final order at Kolkata.

2. PART II - PURPOSE OF THE BID

The purpose of this bid is to identify a manufacturer to supply appropriate scan suits in the defined time frame as per the specifications.

2.1. Recruitment of Bidder

NIFT will have the overall responsibility for the implementation of INDIAsize project. However, considering the magnitude of the scan suits required, a reputable Firm/Agency will be hired for supplying scan suits. The selection of these agencies will be done by inviting technical and price bids from all the interested agencies. Quality of the scan suit, price competitiveness and previous experience in carrying out such orders will be important criteria for the selection. A committee constituted for this purpose will evaluate the technical and price bid and recommend the selection of firm/agency for final acceptance by the Competent Authority.

2.2. Scope of Work of Bidder

The proposal should be prepared on the basis of the following scope of work. The bidder should provide on time delivery, as per provided ratio and specified size and measurement specification.

Bidder is required to provide the following as per the distribution specified in Clause 1.4.2.

Scan Suits: This is specific attire required to be worn by the participants while scanning. It consists of a vest as upper garment and leggings as lower garment for women and a vest as upper garment and cycling shorts as lower garment for men. Additionally, cap and mask are also to be provided as part of scanning attire. This scanning attire is to be given away in a carry bag also to be provided by the bidder.

Bidder would be required to supply the following:

1. Women's Vest
2. Women's Leggings
3. Men's Vest
4. Men's Cycling Shorts
5. Unisex Scan cap for both Women & Men
6. Women's Bra
7. Unisex Mask
8. Carry Bag

One set of scan suit will consist of an upper garment, a lower garment, a face mask and a scan cap. A non-woven/ fabric carry bag (size 14" X 10" X 2" with a 36" long strap to hold) will also be provided to each participant for carrying the souvenirs.

Bidder shall procure cloth, thread and all other materials, tools tackles etc. to complete the work at their own work place only. Bidder shall stitch the scan suit as per the provided specification in the desired size ratio to fit to all samples as required.

2.2.1 Tech Packs

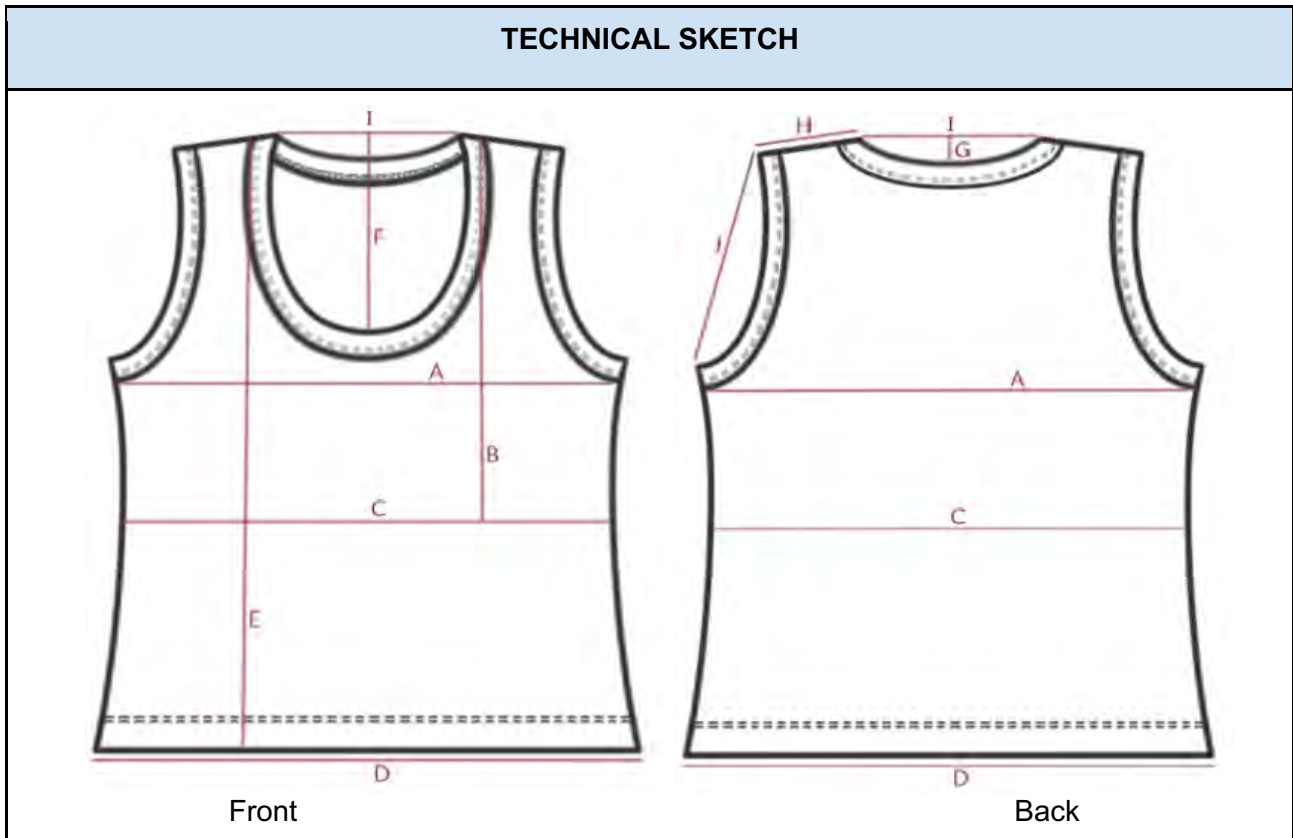

The specifications of the scan suits are as described in the following tech packs.

Tech Pack: Women's Vest			
SKETCH			
		<div style="display: flex; justify-content: space-around;"> Front Back </div>	
Description	Body Hugging Sleeveless Vest with Round Neck; Binding Finish on Neck and Armhole (width 3/8"); Flatlock Bottom Hem (width 1") with Single Turn. Logo placed 2" from Centre Front at Armhole level.		
Fabric Type	Knits 1x1 Rib	GSM	190-220
Fabric Composition	95% Cotton 5% Spandex	Logo Color and Size	Black; 2"X 1.5"
Fabric Color	Red (PANTONE 18-1660 TCX Tomato)	Logo Type	Heat Transfer Print/Screen Print
Sewing Thread	Spun Polyester Thread, 120 Ticket No. (24 Tex), DTM (Dye-to-Match)	Stitches	Side Seams to be done with minimum 3-T O/L (stitch type 504) OR 4- T O/L (stitch type 514 or 512) will also be accepted Bottom Hems (width 1") to be done with stitch 406, and Neck/armhole finish with Binding (width 3/8") to be done using stitch 406. SPI: 10-12 Stitches/Inch



MEASUREMENT CHART

Number of sizes		1	2	3	4	5	6	7	8
Size Label on Scan Suit Women's Vest		XXS	XS	S	M	L	XL	XXL	XXXL
POM	Landmark	Measurement in Inches							
A	Chest Girth	22	23 1/2	25	26 1/2	28	29 1/2	31	32 1/2
B	Waist Level from HPS	13	13 3/8	13 3/4	14 1/8	14 1/2	14 7/8	15 1/4	15 5/8
C	Waist Girth	17 1/2	19	20 1/2	22	23 1/2	25	26 1/2	28
D	Bottom Hem Girth	20 1/2	22	23 1/2	25	26 1/2	28	29 1/2	31
E	Length from HPS	18	19	20	21	22	23	24	25
F	Front Neck Drop from HPS	5 1/2	5 1/2	6	6	6	6 1/2	6 1/2	6 1/2
G	Back Neck Drop from HPS	3	3	3 1/2	3 1/2	3 1/2	4	4	4
H	Shoulder Strap width	2	2	2	2	2	2	2	2
I	Neck Width Edge to Edge	6	6	6 1/2	6 1/2	6 1/2	7	7	7
J	Armhole Depth	7	7	7 1/2	7 1/2	7 1/2	8	8	8

Tech Pack: Women's Leggings			
SKETCH			
			
Front		Back	
Description	Body Hugging Legging with Elasticated 1" Waistband; Three Quarter Leg Length; Flatlock Bottom Hem (width 1") with Single Turn. Logo placed 2" from top of the waistband and 3" in from the side seam.		
Fabric Type	Knits Single Jersey	GSM	200-220
Fabric Composition	95% Cotton 5% Spandex	Logo Color and Size	Black; 2"X 1.5"
Fabric Color	Red (PANTONE 18-1660 TCX Tomato)	Logo Type	Heat Transfer Print/Screen Print
Sewing Thread	Spun Polyester Thread, 120 Ticket No. (24 Tex), DTM (Dye-to-Match)	Stitches	Side Seams and rise to be done with minimum 3-T O/L (stitch type 504) OR 4- T O/L (stitch type 514 or 512) will also be accepted Mobilon tape finish of 6mm on front and back rise Bottom Hems (width 1") to be done with Stitch 406, Waistband to be done with Elastic attach SPI: 10-12 Stitches/Inch

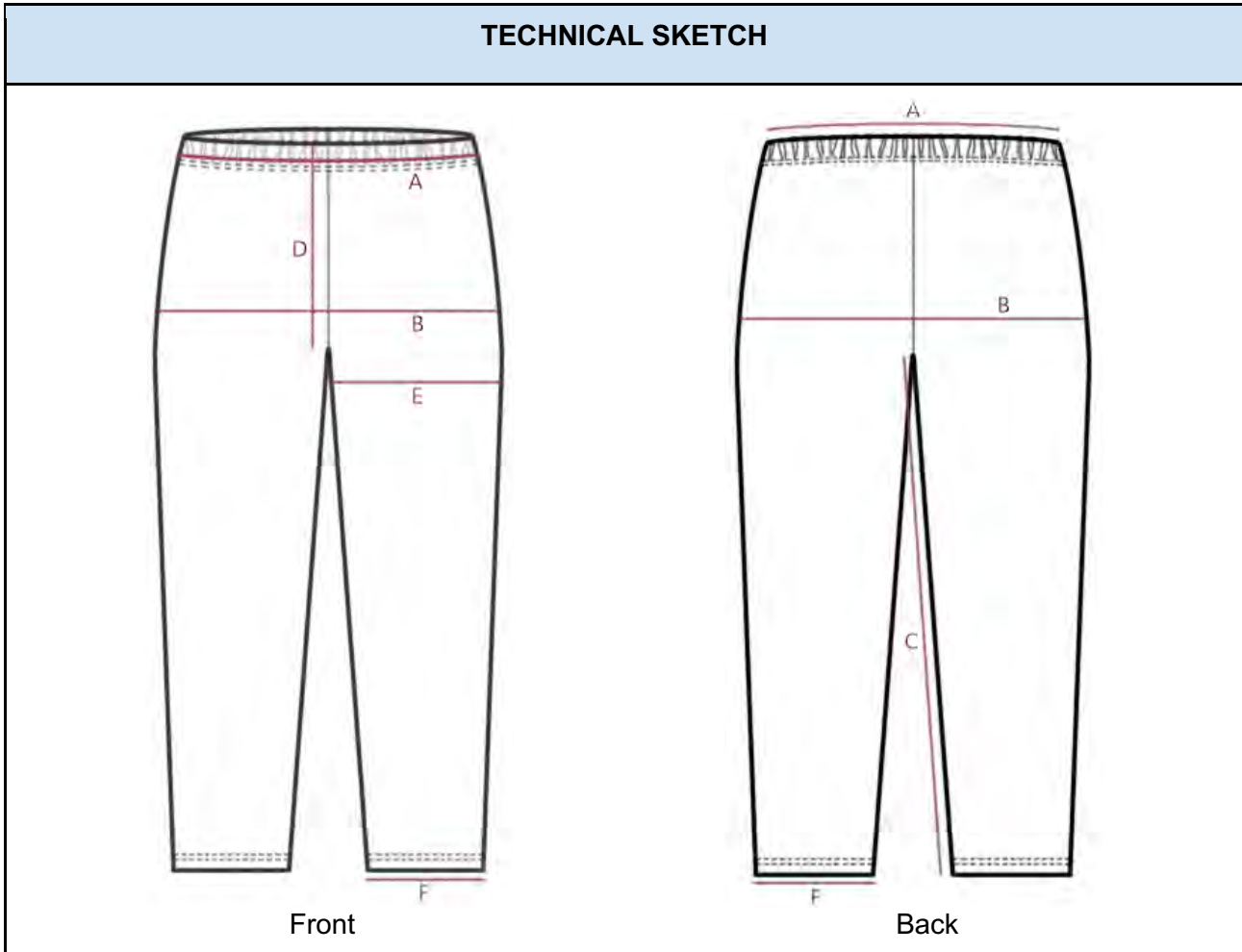

MEASUREMENT CHART

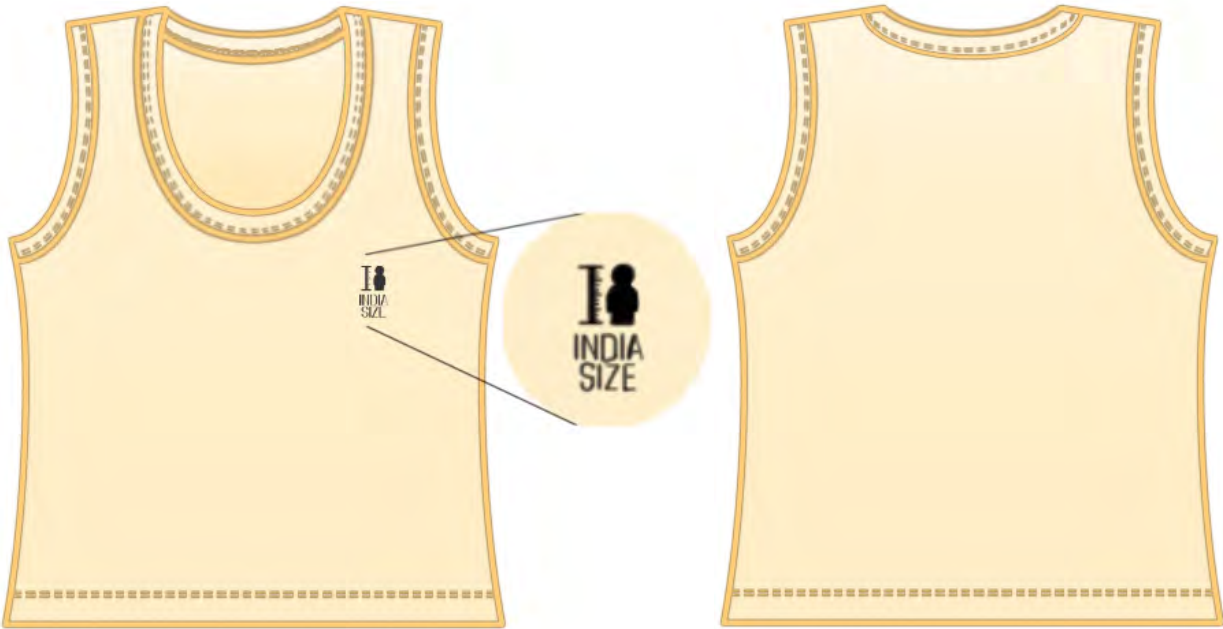

Number of sizes		1	2	3	4	5	6	7	8
Size Label on Scan Suit Women's Leggings		XXS	XS	S	M	L	XL	XXL	XXXL
POM	Landmark	Measurement in Inches							
A	Waist Girth	18	20	22	24	26	28	30	32
B	Hip Girth	26	28	30	32	34	36	38	40
C	Inseam Length	17	17 1/2	18	18 1/2	19	19 1/2	20	20 1/2
D	Crotch Level	7 3/4	8	8 1/4	8 1/2	9	9 1/2	10	10 1/2
E	Half Thigh Girth (1" below crotch)	6 1/2	7 1/4	8	8 3/4	9 1/2	10 1/4	11	11 3/4
F	Hem Girth	7 1/2	8	8 1/2	9	9 1/2	10	10 1/2	11

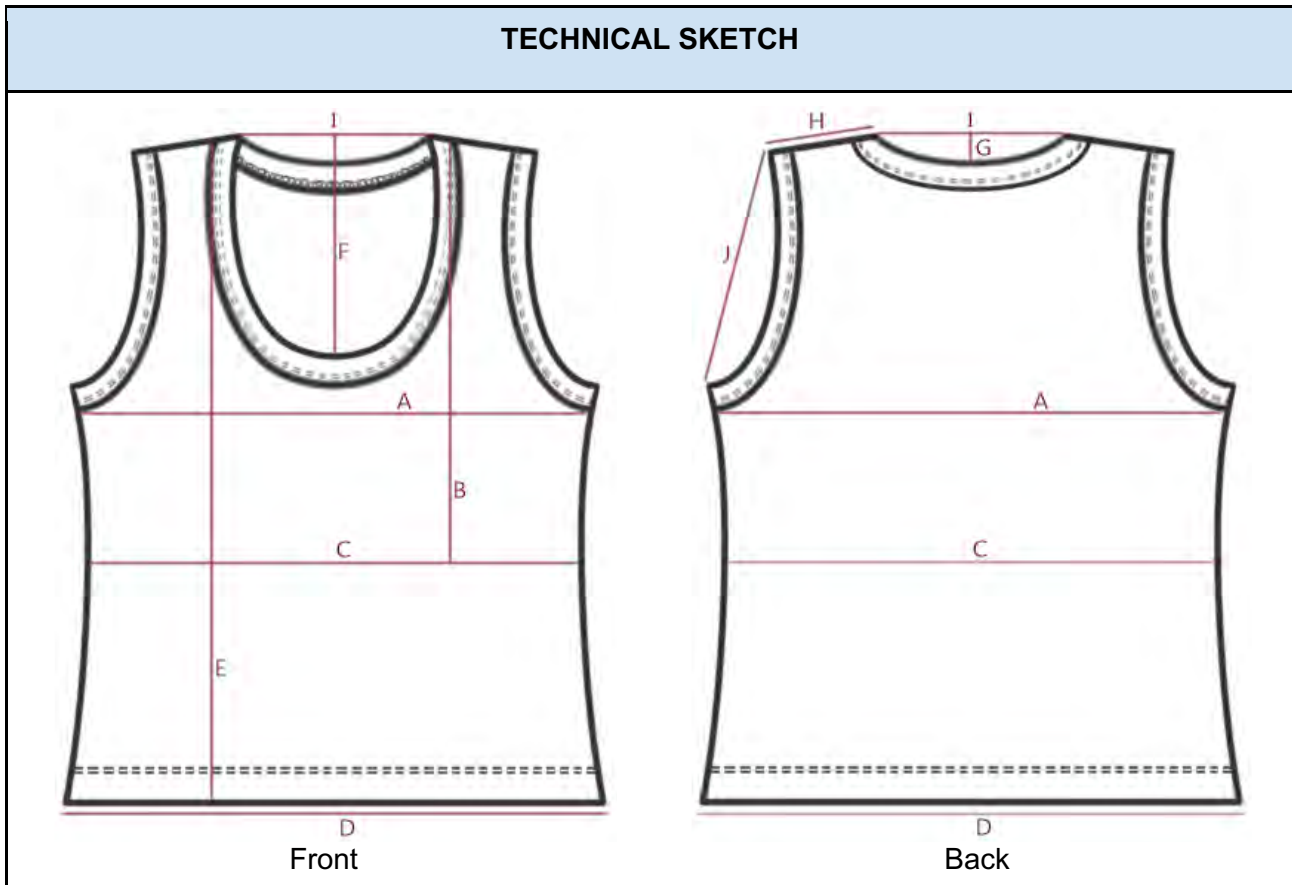
Tech Pack: Men's Vest			
SKETCH			
			
Front		Back	
Description	Body Hugging Sleeveless Vest with Round Neck; Binding Finish on Neck and Armhole (width 3/8"); Flatlock Bottom Hem (width 1") with Single Turn. Logo placed 2" from Centre Front at Armhole level.		
Fabric Type	Knits 1x1 Rib	GSM	190-220
Fabric Composition	95% Cotton 5% Spandex	Logo Color and Size	Black; 2"X 1.5"
Fabric Color	Beige (PANTONE 14-1118 TPX Beige)	Logo Type	Heat Transfer Print/Screen Print
Sewing Thread	Spun Polyester Thread, 120 Ticket No. (24 Tex), DTM (Dye-to-Match)	STITCHES	Side Seams to be done with minimum 3-T O/L (stitch type 504) OR 4- T O/L (stitch type 514 or 512) will also be accepted Bottom Hems (width 1") to be done with stitch 406, and Neck/armhole finish with Binding (width 3/8") to be done using stitch 406. SPI: 10-12 Stitches/Inch



MEASUREMENT CHART

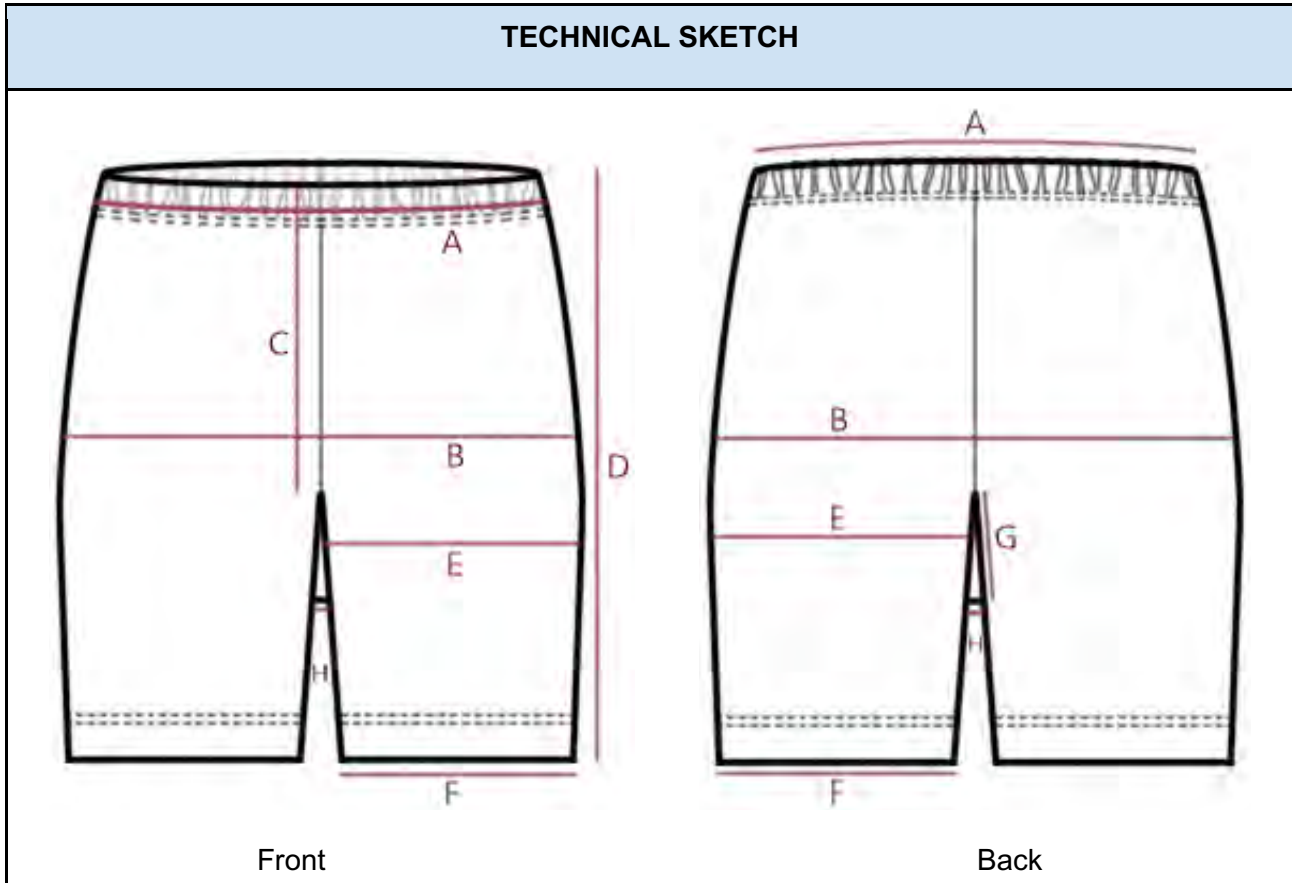

Number of sizes		1	2	3	4	5	6	7	8
Size Label on Scan Suit Men's Vest		XXS	XS	S	M	L	XL	XXL	XXXL
POM	Landmark	Measurement in Inches							
A	Chest Girth	20	22	24	26	28	30	32	34
B	Waist Level from HPS	16	16	16 1/2	16 1/2	16 1/2	17	17	17
C	Waist Girth	19	21	23	25	27	29	31	33
D	Bottom Hem Girth	20	22	24	26	28	30	32	34
E	Length from HPS	21 1/2	22 1/2	23 1/2	24 1/2	25 1/2	26 1/2	27 1/2	28 1/2
F	Front Neck Drop from HPS	6 1/2	6 1/2	7	7	7	7 1/2	7 1/2	7 1/2
G	Back Neck Drop from HPS	2 1/4	2 1/4	2 1/4	2 1/4	2 1/4	2 1/4	2 1/4	2 1/4
H	Shoulder Strap width	2	2	2	2	2	2	2	2
I	Neck Width Edge To Edge	6	6	6 1/2	6 1/2	6 1/2	7	7	7
J	Armhole Depth	8 1/2	8 1/2	9	9	9	9 1/2	9 1/2	9 1/2

Tech Pack: Men's Shorts			
SKETCH			
			
Front		Back	
Description	Body Hugging Legging with Elasticated 1" Waistband; Above knee Length; Flatlock Bottom Hem (width 1") with Single Turn. Logo placed 2" from top of the waistband and 3" in from the side seam.		
Fabric Type	Knits Single Jersey	GSM	200-220
Fabric Composition	95% Cotton 5% Spandex	Logo Color and Size	White; 2"X 1.5"
Fabric Color	Black (PANTONE 19-0303 TCX Jet Black)	Logo Type	Heat Transfer Print/Screen Print
Sewing Thread	Spun Polyester Thread, 120 Ticket No. (24 Tex), DTM (Dye-to-Match)	Stitches	Side Seams and rise to be done with minimum 3-T O/L (stitch type 504) OR 4- T O/L (stitch type 514 or 512) will also be accepted Mobilon tape finish of 6mm on front and back rise. Bottom Hems (width 1") to be done with Stitch 406, Waistband to be done with Elastic attach SPI: 10-12 Stitches/Inch

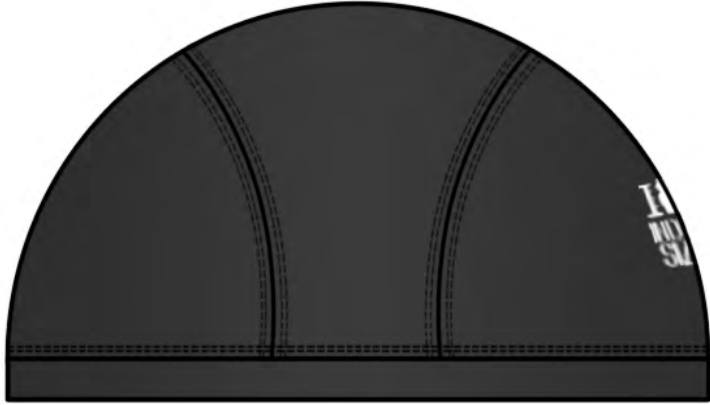

MEASUREMENT CHART

Number of sizes		1	2	3	4	5	6	7	8
Size Label on Scan Suit Men's Shorts		XXS	XS	S	M	L	XL	XXL	XXXL
POM	Landmark	Measurement in Inches							
A	Waist Girth	14	16	18	20	22	24	26	28
B	Hip Girth	25	27	29	31	33	35	37	39
C	Crotch level	9	9 1/4	9 1/2	9 3/4	10	10 1/4	10 1/2	10 3/4
D	Out seam Length	15 1/2	16	16 1/2	17	17 1/2	18	18 1/2	19
E	Half Thigh Girth (1"below crotch)	5 3/4	6 1/8	6 1/2	6 7/8	7 1/4	7 5/8	8	8 3/8
F	Hem Girth	11	11 3/4	12 1/2	13 1/4	14	14 3/4	15 1/2	16 1/4
G	Gusset Length	5 3/4	6 1/8	6 1/2	6 7/8	7 1/4	7 5/8	8	8 3/8
H	Gusset Width	2 1/2	2 3/4	3	3 1/4	3 1/2	3 3/4	4	4 1/4

Tech Pack: Scan Cap			
SKETCH			
 <p style="text-align: center;">Front</p>			
 <p style="text-align: center;">Side</p>			
Description	Scan Cap with two semi-circular side panels and one center panel with a band at the bottom; all attached with a Flatlock seam. Logo placed in the center of the left side panel.		
Fabric Type	Knit 1X1 Rib	GSM	190- 220
Fabric Composition	95% Cotton 5% Spandex	Logo Color and Size	White; 2”X 1.5”
Fabric Color	Black (PANTONE 19-0303 TCX Jet Black)	Logo Type	Heat Transfer Print/Screen Print
Sewing Thread	Spun Polyester Thread, 120 Ticket No. (24 Tex), DTM (Dye-to-Match)	Stitches	The cap panels to be attached using stitch 602. Cap band to be attached with stitch 504 and top stitched with stitch 406. SPI: 10-12 Stitches/Inch

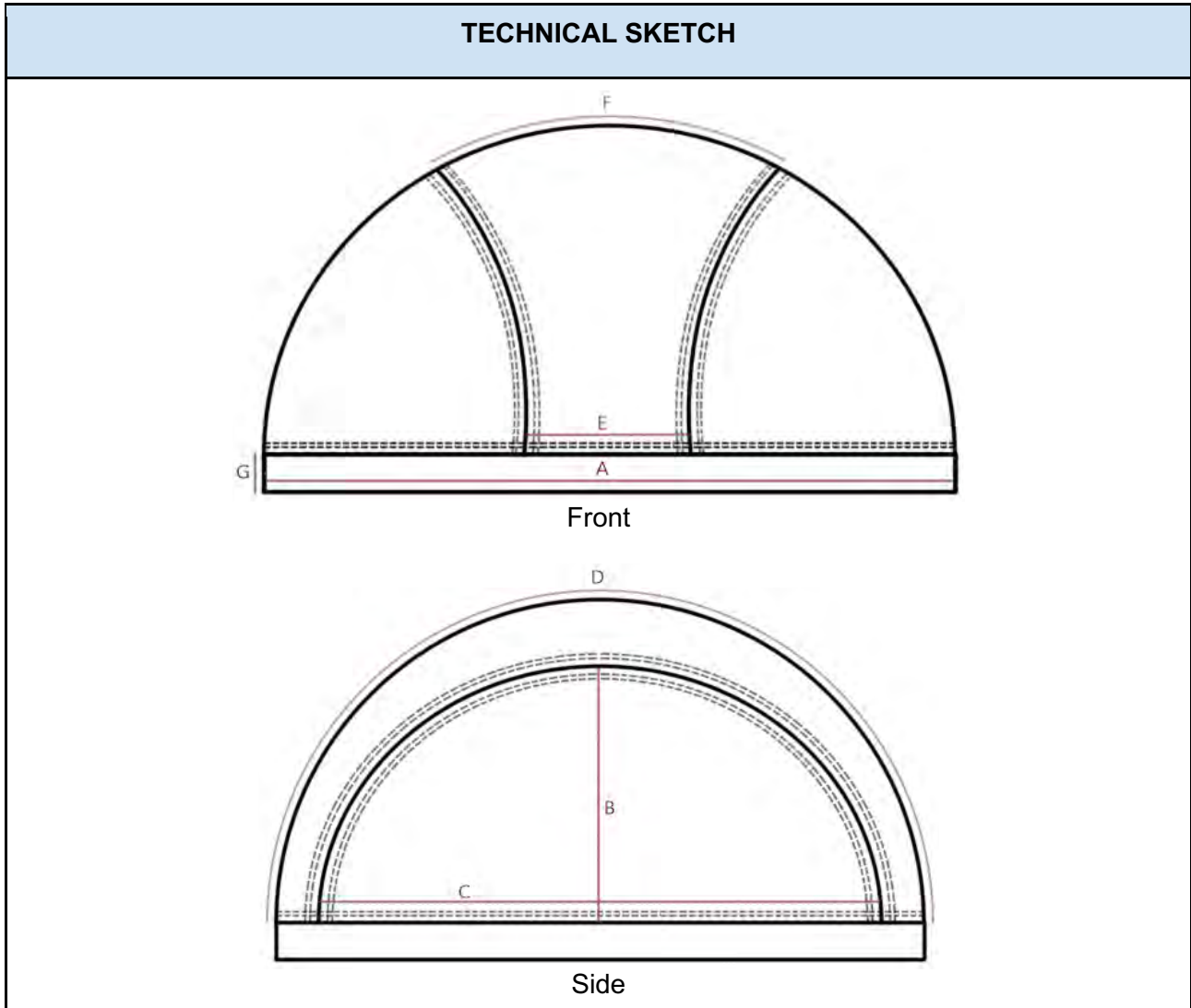

MEASUREMENT CHART



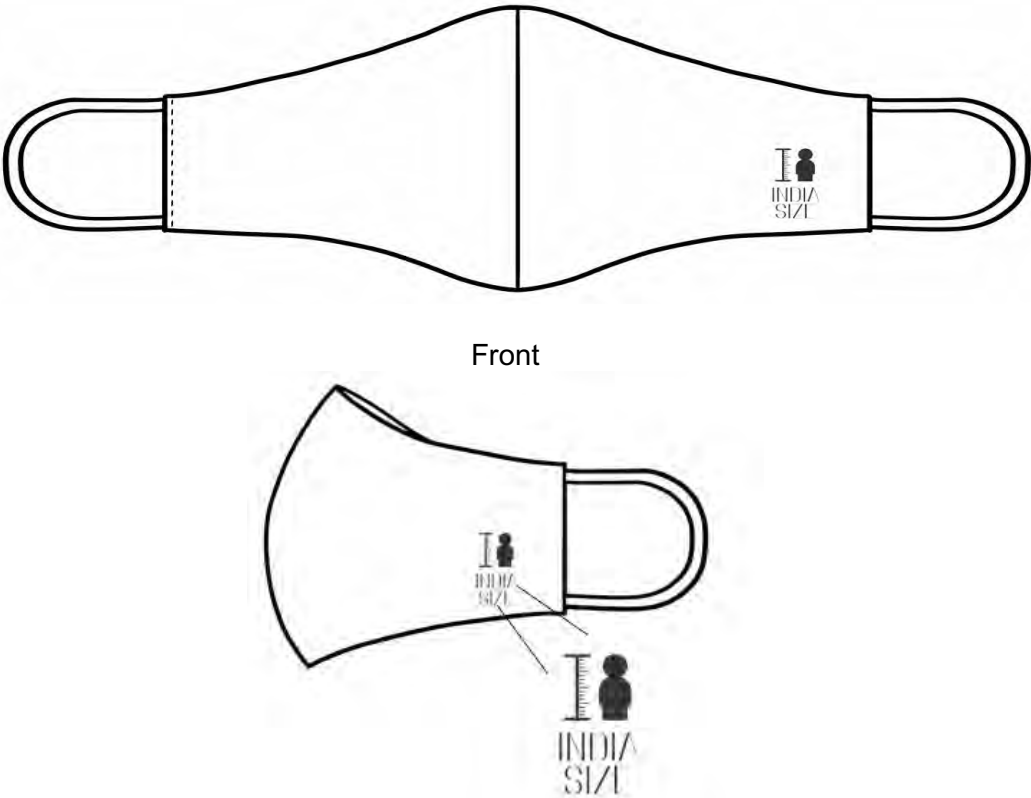

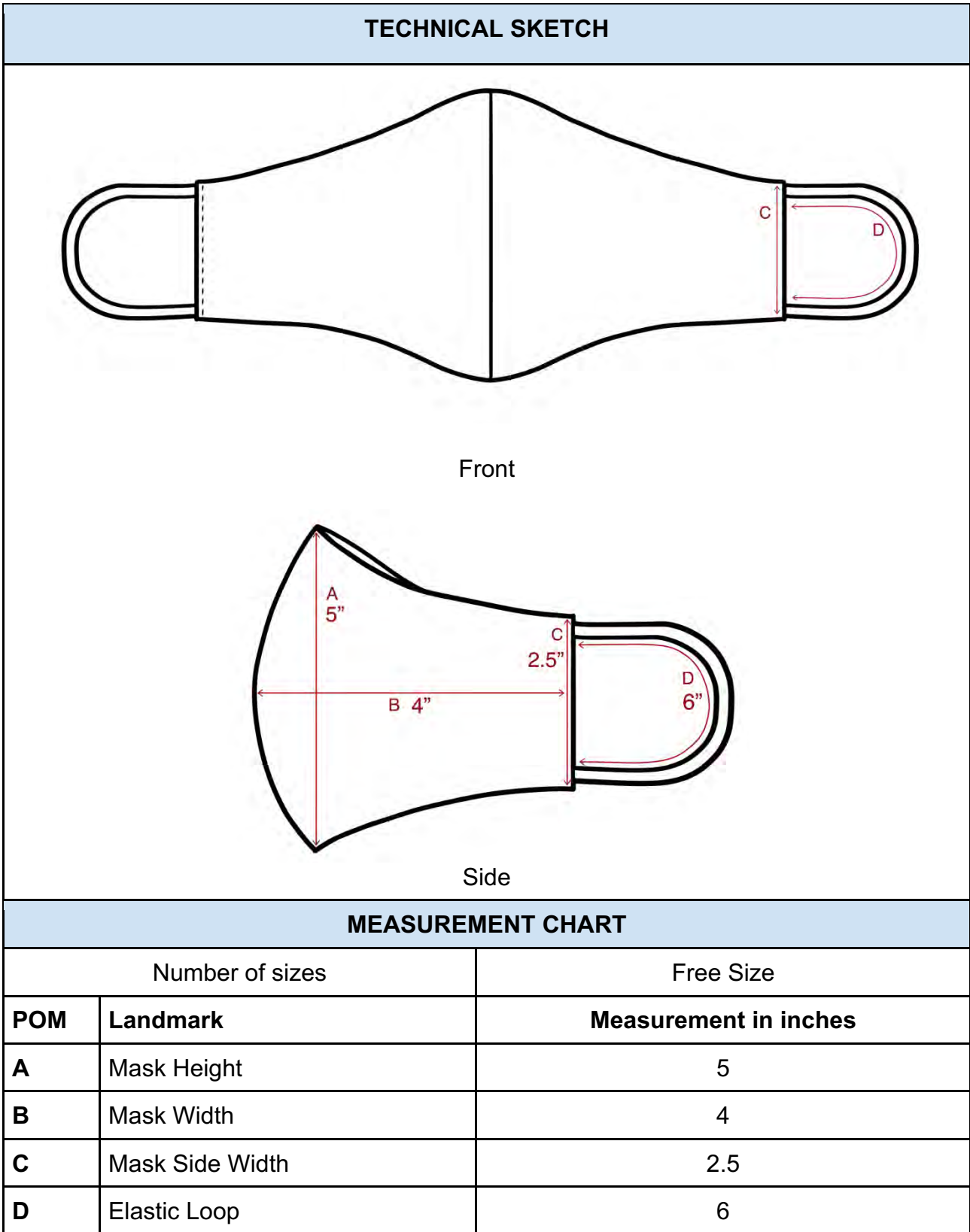
Number of sizes		Free Size
POM	Landmark	Measurement in Inches
A	Cap Circumference	21
B	Side Panel Height	4
C	Side Panel Width	7 1/2
D	Center Panel Length	13
E	Center Panel Bottom Width	3 1/2
F	Center Panel Center Width	4 1/2
G	Cap Band Height	1





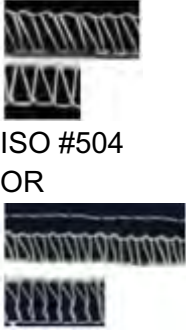
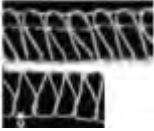

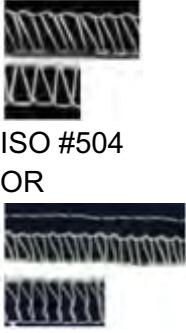
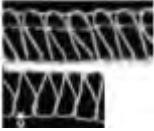
Tech Pack: Face Mask			
SKETCH			
 <p style="text-align: center;">Front</p> <p style="text-align: center;">Side</p>			
Description	Double-layered face mask with center seam and two elastic loops at sides. Logo placed in the bottom left corner of the mask (As shown in sketch)		
Fabric Type	Knits Single Jersey	GSM	200-220
Fabric Composition	95% Cotton & 5% Spandex or 100% Cotton	Logo Color and Size	Black; 1.5"x 1.25"
Fabric Color	Beige (PANTONE 14-1118 TPX Beige)	Logo Type	Heat Transfer Print/ Screen Print
Sewing Thread	Spun Polyester Thread, 120 Ticket No. (24 Tex), DTM (Dye-to-Match)	Stitches	Double-layered face mask to be closed at top and bottom with binding (width 3/8"). Sides of the mask (with ear loops) should be closed as inside-out using SNLS. SPI: 10-12 Stitches/Inch







Please Note: All samples to be approved for quality of material, logo (print, size & placement) and construction by NIFT before final production.

Stitch and Seam details

Name	Type	Reference Image	Stitch/Seam Diagram
Side Seams (Top)	Minimum 3-T O/L (stitch type 504) OR 4- T O/L (stitch type 514 or 512)		 <p>ISO #504 OR ISO #512</p>  <p>ISO #514</p>
Shoulder Join	Minimum 3-T O/L (stitch type 504) OR 4- T O/L (stitch type 514 or 512)		 <p>ISO #504 OR ISO #512</p>  <p>ISO #514</p>
Armhole and Neck finish	Neck finish with Binding to be done with stitch type 406.		

<p>Hemming (Top)</p>	<p>Stitch type 406</p>		
<p>Front Rise and Back Rise (Bottom)</p>	<p>Minimum 3-T O/L (stitch type 504) OR 4- T O/L (stitch type 514 or 512) with 6mm width Mobilon tape</p>		 <p>ISO #504 OR ISO #512 OR ISO #514</p>
<p>Out Seams (Bottom)</p>	<p>No Seam – ON FOLD</p>	<p>No Seam – ON FOLD</p>	
<p>Inseams (Bottom)</p>	<p>Minimum 3-T O/L (stitch type 504) OR 4- T O/L (stitch type 514 or 512)</p>		 <p>ISO #504 OR ISO #512 OR ISO #514</p>

<p>Hemming (Bottom)</p>	<p>Stitch type 406</p>		
<p>Waist Band (Bottom)</p>	<p>Waistband with Elastic attach Width – 1”</p>	<p>The Waistband with Elastic can be done as: Serging Shell fabric and Elastic with 3 T O/L (Stitch 504) , then Turn and apply Multi-Needle Chain Stitch (Popularly known as KANSAI) OR Serging Shell fabric and Elastic with 3 T O/L (Stitch 504), then Turn and apply Flat Lock (Stitch 406)</p>	
<p>Crotch (Male)</p>	<p>Minimum 3-T O/L (stitch type 504) OR 4- T O/L (stitch type 514 or 512)</p>		 <p>ISO #504 OR ISO #512 OR ISO #514</p>
<p>Cap panel attach</p>	<p>To be joined with stitch 602 or stitch 607</p>		

Women's Bra

Bidder will be required to source and supply the Women Brassiere in the following set size. Material should be cotton Knit /Woven fabric. Basic design with minimum seams, no underwires or padding.

The successful bidder would have to get the samples approved by NIFT.

Description & Size set

Size	34B	36B	38B	40B	42B
Total Quantity	700	1500	1500	1000	400
1st order	350	750	750	500	200
2nd Order	175	375	375	250	100
3rd Order	175	375	375	250	100

Carry Bag

Non-woven/ Woven Fabric tote bag of size 14" X 10" X 2" with a 36" long shoulder strap (width 1.5") with logo printed in the center of 6"x4.5" height, to accommodate all the pieces of the scan suit set.

2.2.2 Delivery and Transportation of the Scan Suits

The ready stitched scan suit sets have to be delivered at the site of NIFT Campuses in 3 cities (Delhi, Chennai and Kolkata), as mentioned in clause 1.4.2.

The Bidder shall follow the following packing instructions while shipping the scan-suits

1. Solid packing method to be followed with 1 set (upper garment-1, lower garment-1, face mask-1, scan cap-1, and carry bag-1) to be packed in a single transparent poly-bag. Each transparent polybag should also have a Silica gel pouch/bag to avoid excess moisture and prevent garments from any odour and fungus.
2. The packs (as indicated in point 1) should be assorted Size wise and gender wise, with clear marking (of Size and Gender) on each of the packs.
3. The Carton should have clear mention of assortment inside the carton in terms of size, gender, number of sets, and the carton number. Preferably 150- 200 sets should be packed per Carton.
4. The packing list with carton number and contents of the carton to be essentially submitted along with each of the consignments.

2.2.3 Samples to be submitted with the Technical Bid

The Bidder shall submit One complete scan suit set (Proto Sample) with the actual or nearest possible fabrics and trims. The sample submitted should be for male and female as per the measurements specifications of any one size (preferably medium size of the size range).

2.2.4 Inspection Authority

1. Prior to starting the bulk production, the Bidder needs to submit a complete set as per the specifications for males and females scan suits, cap and mask.
2. The necessary amendments related to fit, quality, shade, or material, etc. of the scan suit (if observed as deviations from the specifications in suits submitted as per point 1) to be undertaken by the supplier.
3. On the start of bulk production, NIFT officials shall approve the TOP (Top of Production) samples on-site.
4. The final garments to be inspected by the NIFT officials at each of the delivery. The supplier to submit its internal QA reports duly signed by the authority responsible at the manufacturing site.
5. In case of any defect/deviations from specifications like ill-fit, variation of shade, etc., the stitched supplied items are to be replaced by the supplier at its own cost.

It is essential to submit the report of Garment testing on mentioned parameters (following suitable standard methods- ISO/ASTM/AATCC) performed by a third-party government approved testing agency (such as SGS, ITS, Bureau Veritas etc.). The test to be undertaken are as follows:

- 1. Physical Tests** – Fibre Content – Fabric (Up to 2 fibre), Fabric Construction, GSM
 - **Fabric Weight/GSM** - ASTM D3776 (As approved Sample +/- 5%)
 - **Fibre Content (Up to Two fibers)** - AATCC 20-A (As approved Sample +/- 3 %)
- 2. Colour Fastness Tests** - Crocking / Rubbing and Perspiration
 - **Color Fastness to Crocking/Rubbing**
Method : AATCC 8
The requirement to PASS the test (for Cotton Material)
Dry - 3 and Above (On the standard scale of 5)
Wet - 2- 3 (On the standard scale of 5)
 - **Color Fastness to Perspiration**
Method : AATCC 15
The requirement to PASS the test (for Cotton Material)
Colour Change - 3 and Above (On the standard scale of 5)
Colour Staining - 3 and Above (On the standard scale of 5)

Based on recommendation(s) of testing result, if the sample(s) does not meet(s) the requirement of tender specification with respect of the test carried out by testing agency,

payment will not be released and PBG deposited with tender will be forfeited immediately and the firm will be blacklisted, with approval of the Competent Authority.

2.3. Role and Responsibility of Bidder

2.3.1 Compensation

2.3.1.1 Workmen's Compensation

It shall be the responsibility of the Bidder to pay the workmen's compensation and comply with the laws of the land. However in every case in which by virtue of the provisions of Section 12, sub-section (i) of the Workmen's compensation Act, 1923 NIFT is obliged to pay compensation to a workman employed by the Bidder, in execution of the works, NIFT shall recover from the Bidder the amount of the compensation so paid; and without prejudice to the rights of the NIFT under Section 12 Sub-section (ii) of the said Act, NIFT shall be at liberty to recover such amount or any part thereof by deducting it from the Security Deposit or from any sum due by NIFT to the Bidder whether under this contract or otherwise. Government shall not be bound to contest any claim made against it under Section 12 sub-section (i) of the said Act, except on the written request of the Bidder and upon his giving to NIFT full security for all costs for which NIFT might become liable in consequence of contesting such claim.

2.3.1.2 Labour Welfare

- a. During continuance of the contract, the contractor shall abide at all times by the existing labour enactments and rules made there under, regulations, notification and by laws of state or central government or local authority and any other labour law (including rules, regulations, bylaws that may be passed or notification that may be issued under any labour law in future either by the state or central government or local authority
- b. The Bidder shall keep NIFT indemnified in case of any action taken against NIFT by the competent authority on account of contravention of any of the provisions of any Act or rules made thereunder, regulations, by laws, amendments that may be passed or notification that may be issued under any labour law in future either by the state or central government or local authority
- c. If NIFT is caused to pay, reimburse such amount as may be necessary to cause or observe, or for on observance of the provisions stipulated in the notification/ bylaws / Acts/ Rules/ regulations including amendments, if any, on part, the NIFT shall have right to recover from the Bidder any some required or estimated to be required for making good the laws or damage suffered by the NIFT.
- d. The employees of the Bidder in no case shall be treated as the employees of the NIFT at any point of time.
- e. The employer is bound to fulfil the terms and conditions for compliance of the provision of EPF & Misc. Provision Act 1952, and Employee Provident Fund Scheme 1952 by the Bidder in respect of employees hired by him for performing works under the Contract.

- f. Any failure to fulfil this requirement shall attract the penal provisions of this contract arising out of the resultant non-execution of the work.
- g. No labourer below the age of eighteen years shall be employed on the work.

2.3.1.3 Fair Wages

- a. The Bidder shall pay to labour employed by him either directly or through his authorized representative, wages not less than fair wages as defined in the C.P.W.D. Bidder's labour regulations or as per the provisions of the contract labour (Regulation and abolition) Act and the Contract Labour (Regulation and Abolition) Central Rules, wherever applicable.
- b. The Bidder shall, notwithstanding the provisions of any contract to the contrary, cause to pay fair wage to labour indirectly engaged on the work.
- c. In respect of all labour directly or indirectly employed in the works for performance of the contract's part of this agreement, the Bidder shall comply with or cause to comply with the Central Public Works Departmental Bidder's Labour Regulation made by the NIFT from time to time in regard to payment of wages, wage period, deduction from wages, recovery of wages not paid and deduction unauthorized made, maintenance of wages book or wage slips, publication of scale of wages and other terms of employment, inspection and submission of periodical returns and full other matters of the like nature of as per the provisions of the Contract Labour (Regulation & Abolition) Central Rules 1977 wherever is applicable.
- d. The Bidder shall comply with the provisions of the Payment of Wages Act 1936, Minimum Wages 1948, Employees Liability Act 1938, Workmen's Compensation Act 1923, Industrial Disputes Act, 1947, Maternity Benefits Act 1961, and the Bidder's about (Regulation and Abolition) Act or the modifications thereof or any other laws relating thereto and the rules made thereunder from time to time.
- e. The Bidder shall indemnify NIFT against payments to be made under and for the observance of the Laws aforesaid without prejudice to its right to claim indemnity from Bidders.
- f. The regulations aforesaid shall be deemed to be a part of this contract and any breach thereof shall be deemed to be a breach of this contract.

2.3.1.4 Other Consideration of Bidder

- a. Bidder shall be required to extend full cooperation to the monitoring personnel from the NIFT HO/NIFT Campuses or third party appointed by NIFT for this purpose.
- b. Bidder is strictly advised to refrain from extending any undue favours to any staff of NIFT or other monitoring staff. NIFT reserves the right to take appropriate action if any such incidents are brought to the notice of NIFT. Any direct or indirect interference that hinders the monitoring and supervision work can amount to termination of the contract along with suitable penalty. NIFT may blacklist the agency if it is found to be involved in any such malpractices.
- c. All costs related to transporting any materials from Bidder to NIFT and back in case of quality problem must be borne by Bidder.

- d. The Bidder is mandatorily required to adhere to the given time while meeting the sampling framework. In case of non-adherence to time frame penalty will be levied on the Bidder.
- e. The rates quoted in the price bid shall be inclusive of all charges on account of loading, unloading and transportation at all NIFT centers as mentioned in the delivery schedule.
- f. No extra charges for packing, forwarding and insurance etc. will be paid on the rates quoted.
- g. The successful Bidder has to supply the goods strictly as per specification/sample and within prescribed time limit. If the material supplied is not found as per the specification/sample/inferior in quality, the entire supply order is liable for cancellation and PBG paid will be forfeited to the government and said agency shall be blacklisted.

3. PART III- GUIDELINES FOR SUBMITTING THE BID

3.1. Information on Bid

1. The Bid document in English may be downloaded free of cost from CPP Portal <https://nifttenders.eproc.in> and NIFT website www.nift.ac.in, from 21.10.2020 at 1800 Hours (IST).
2. A Pre-bid meeting to explain the exact scope of the work and to resolve queries of the participating agencies will be organized by NIFT on 02.11.2020 at 1100 Hours (IST) online or in the Boardroom of NIFT HO, Hauz Khas, New Delhi.
3. Interested agencies will be required to register online as indicated in Clause 3.3 Process of Online Registration.
4. The Bids (both Technical and Price bid) have to be submitted through online only. The responsibility to ensure this lies with the Bidder.
5. The Bidder is expected to examine all instructions, forms, terms, and specifications in the Bidding Documents. Failure to furnish all information required by the tender or submission of a bid not substantially responsive to the tender [in every respect] will be at the Bidder's risk and may result in rejection of bid.
6. Last Date and Time for submitting the Bids: on 17.11.2020 at 1500 Hours (IST).

3.2. Preparation of the Bid

1. After downloading the bid document, the Bidder should go through it carefully to understand the documents required to be submitted as part of the bid.
2. Bidder shall take into account any corrigendum published on the bid document before submitting their bids.
3. It is construed that the Bidder has read all the terms and conditions before submitting their offer.
4. Bidder must sign the undertaking attached in Annexure VI regarding the Tender Acceptance Letter.
5. The Bidder, in advance, should get ready the bid documents to be submitted as indicated in the bid document and generally, they can be in PDF / XLS / RAR / DWF/JPG formats.
6. Bid documents may be scanned with 100 dpi with black and white option which helps in reducing the size of the scanned document.

3.3. Process of Online Registration

1. Applications to this tender shall be accepted only through the online mode through <https://nifttenders.eproc.in>.
2. No other mode of application shall be considered.
3. For applying online, the firm shall get itself registered at <https://nifttenders.eproc.in> by paying online.
4. As part of the enrolment process, the Bidders shall be required to mention his Company name, address, choose a unique username and assign a password for their accounts.

5. Bidders are advised to register their valid email address and mobile numbers as part of the registration process. These would be used for any communication from the CPP Portal.
6. Registration Charges of Rs. 2000/- + 360/- (18%GST) = Rs. 2,360/- (Two Thousand Three Hundred Sixty only – Non refundable are to be borne by Bidder) to be made through NEFT.
7. Bid Processing Fee charges of Rs. 5000 + 900 (18%GST) = Rs. 5,900 (Five thousand and nine hundred only, non refundable) to be made through NEFT.
8. Bidders need to send the scanned copies of UTR number to anjal.garg@c1india.com and sandeep.bhandari@c1india.com mentioning their Company name, address and User ID for approval of Registration and Bid ID and Bid Title for Approval of Bid Processing fees.
9. Upon enrolment, the Bidders shall be required to register their valid Digital Signature Certificate (Class II or Class III Certificates with signing key usage) issued by any Certifying Authority recognized by CCA India (e.g. Sify / nCode / eMudhra etc.), with their profile.
10. A Bidder shall register only one valid DSC. Please note that the Bidders are responsible to ensure that they do not lend their DSC's to others, which may lead to misuse.
11. Bidder then logs in to the site through the secured log-in by entering their user ID / password and the password of the DSC / e-Token.
12. The basic requirements for registration and applying for bid online are as under:
 - Operating System should be Windows 7 and above.
 - Java version: Java 8 update 25.
 - Internet Explorer 11 and above or Mozilla Firefox.
 - All java add-ons must be enabled in the system.
 - Use Class III B Digital Signature Certificates (DSC) having Signing and Encryption both.

3.4. Online Submission of Bid

1. The interested Bidders are required to apply online and submit soft copies of their bids along with scanned copies of all the relevant documents in support of their technical & price bids electronically, all duly signed, using valid Digital Signature Certificates, on the <https://nifttenders.eproc.in> from 21.10.2020 at 1800 Hours (IST) up to 17.11.2020 at 1500 Hours (IST).
2. The Bid document would also be available for viewing on the “bids” link of the NIFT website i.e. <https://nifttenders.eproc.in>; <http://www.nift.ac.in>.
3. The Bidder should log into the site well in advance for bid submission so that they can upload the bid in time i.e. on or before the bid submission time. Bidder shall be responsible for any delay due to other issues.
4. The Bidder has to digitally sign and upload the required bid documents one by one as indicated in the bid document.

5. The Bidder shall prepare the EMD as per the instructions specified in the tender in Clause 4.2 on EMD. The original shall be posted/couriered/given in person to the concerned official, latest by before bid opening date/time as mentioned in the date sheet or as specified in the tender. The details of the DD/any other accepted instrument, physically sent, shall tally with the details available in the scanned copy and the data entered during bid submission time. Otherwise the uploaded bid shall be rejected.
6. The Bidder is advised to attach any additional information that is considered necessary to establish its capabilities.
7. No further information shall be entertained after submission of Bid application unless it is required by NIFT. However, NIFT reserves the right to call for clarification on information and documents submitted by the Bidders.
8. The server time shall be considered as the standard time for referencing the deadlines for submission of the bids by the Bidders, opening of bids etc. The Bidders shall follow this time during bid submission.
9. Online price bid shall be filled only as per Annexure - III.
10. The bid summary has to be printed and kept as an acknowledgement of the submission of the bid.
11. Proposals received after the due date and time specified shall be automatically rejected.
12. Any further clarifications can be sought from the service provider for online submission of the bid on e-portal i.e. Mr. Sandeep Bhandari Mobile No. +91 8826814007, alternate number +124 4302033/ 36/ 37.
13. This tender is being issued with no financial commitment and the NIFT reserves the right to change or vary any part thereof or foreclose the procurement case at any stage. The NIFT also reserves the right to disqualify any vendor, should it be necessary, at any stage on grounds of National Security.
14. In case of any query you may contact The Purchase Officer, National Institute of Fashion Technology, NIFT Campus, Near Gulmohar Park, Hauz Khas, New Delhi-110016, Mobile No. +91 9810136563 Phone No. +91 11 26542017/2176, email - purchase.ho@nift.ac.in for grievance related to bidding condition, bidding process, rejection of bid and/or any other clarifications. With regards to the bidding condition, this shall be done in writing at least 7 days in advance of the stipulated date of submission of bid.

4. PART IV - PAYMENT TERMS

4.1. Payment Schedule

The payment terms are as follows-

- (a) All payments will be made through ECS/NEFT after delivery of items and producing of documents and after obtaining satisfactory reports from the Project Team.
- (b) It is mandatory for the Bidder to indicate their bank account number and other relevant e-payment details so that payments can be made through ECS/NEFT mechanism instead of payment through cheques.

Delivery will be done in 3 lots and payment schedule will follow accordingly

- 1st lot - 50% of the scan suits and brassiere
- 2nd lot - 25% of the scan suits and brassiere
- 3rd lot - 25% of scan suits and brassiere

1 ST Instalment of 50% of total lot	Advance payment	20% of the 1st Lot will be paid as advance after placing the order.
	After receipt of 1st Lot of 15000 scan suit + 2500 brassieres	65% of the remaining payment of 1st lot will be released after receiving the scan suits and quality clearance.
	Remaining payment	Remaining 15% will be paid after receipt of last delivery
2 nd Instalment of 25% of total lot	Advance payment	20% of the 2nd lot will be paid as advance confirming the size ratio
	After receipt of 2nd Lot of 7500 scan suit + 1250 brassieres	65% of the remaining payment will be released after receiving the scan suits and quality clearance.
	Remaining payment	Remaining 15% will be paid after receipt of last delivery
3 rd Instalment of 25% of total lot	Advance payment	20% of the 7500 scan suits will be paid as advance confirming the size ratio
	After receipt of 3rd lot of 7500 scan suit + 1250 brassieres	65% of the remaining payment will be released after receiving the scan suits and quality clearance.
	Remaining payment	Remaining entire payment will be paid after receipt of last delivery

4.2. Earnest Money Deposit

The Bidders shall furnish an Earnest Money Deposit (EMD) of Rs. 9,00,000/- (Rupees Nine Lakhs) by means of Demand Draft drawn on any Nationalized Bank / Scheduled Bank payable in favour of the National Institute of Fashion Technology payable at New Delhi. EMD can also be submitted in form of Bank Guarantee with validity for 180 days. Scanned copy of EMD should be submitted along with the technical bids online and original form of EMD should reach NIFT by the day of opening of bid at NIFT, Hauz Khas, New Delhi. The amount of EMD can also be deposited in the provided NIFT's INDIAsize account. Cheque, Cash payment, Money Order, Fixed deposit etc. will not be accepted as EMD. The Bid received without the Earnest Money Deposit shall be summarily rejected by the Accepting Authority as non-responsive.

The Earnest Money Deposit will be refunded after the completion of the selection process as per the GFR 170. The amount remitted towards Earnest Money Deposit is liable to be forfeited in case the Bidder retracts its offer after submission of the bid or after the acceptance of the offer by NIFT or fails to sign the contract or to remit the Security Deposit. No interest shall be payable by the NIFT on the Earnest Money Deposited / remitted.

Successful Bidder's EMD will be returned after submission of Performance Bank Guarantee and the Bidder's acceptance of the Letter of Intent (LOI). NIFT will discharge EMD to each unsuccessful Bidder after completion of the tendering process.

Note: Exemption to SSI, MSME, NSIC etc. as per Government rules.

A proof regarding current registration will have to be attached along with the bid.

4.3. Performance Bank Guarantee (PBG)

Selected Bidder shall have to deposit 10% of the contract value (including all taxes) as Performance Bank Guarantee (PBG) at the time of signing the contract. The selected Bidder shall at his own expense deposit the PBG with NIFT, within fourteen (14) working days of the date of issuing notice of award of the contract or prior to signing of the contract whichever is earlier. An unconditional and irrevocable Performance Bank Guarantee from a Nationalized/ Scheduled bank acceptable to NIFT, payable on demand, for the due performance and fulfillment of the contract by the Bidder.

This PBG should be valid for 13 months or completion of the project whichever is later. All incidental charges whatsoever, such as premium, commission, etc., with respect to the PBG shall be borne by the Bidder. The performance bank guarantee may be discharged/returned by NIFT upon being satisfied that there has been due performance of the obligations of the Bidder under the contract. However, no interest shall be payable on the Performance Bank Guarantee. In case of delay on completion of project the successful Bidder shall have to extend the period of bank guarantee till the completion of project.

5. PART V - GENERAL TERMS AND CONDITIONS

5.1. Language of Bid

The bid prepared by the Bidder, as well as all correspondence and documents relating to the bid exchanged by the Bidder and the NIFT shall be written in the English language.

5.2. Clarification on Bidding Documents

A prospective Bidder requiring any clarification on the Tender Documents shall notify NIFT in writing by e-mail at purchase.ho@nift.ac.in two days prior to the Pre-bid meeting on 02.11.2020. Written copies of the NIFT's response (including an explanation of the query but without identifying the source of inquiry) will be notified on the NIFT website. No change in the prices or substance of the Bid shall be sought, offered, or permitted. No clarification shall be issued after opening of the bid.

5.3. Amendment of Bidding Documents

NIFT may amend the Bid Conditions up to 05 days prior to the time fixed for the last date of the Bid submission. Amendment to the bid, in response to clarifications sought by prospective Bidders, is solely at the discretion of NIFT. Such amendments will be notified on e-procurement CPP portal and NIFT's website. NIFT, at its discretion, may or may not extend the due date and time for the submission of bids on account of amendments. Extension of time, if any, will be notified on e-procurement CPP portal and NIFT's website. All the Bidders are advised to periodically browse CPP Portal (URL: <https://nifttenders.eproc.in>) and NIFT website (URL: <https://www.nift.ac.in>) for any amendments or corrigenda issued in connection with this Bid. NIFT will not be responsible for any misinterpretation of the provisions of this bid document on account of the Bidder's failure to update the bid documents based on changes announced through the website.

5.4. Modification/ Substitution/ Withdrawal of Bids

A Bidder may modify or withdraw his Bid online on the portal till the date of submission of the bid. No bid shall be modified after submission of the bids. No bid may be withdrawn in the interval between the deadline for submission of bids and expiration of the specified period of bid validity.

5.5. Rejection of Bid

- a) Effective competition is lacking.
- b) All bids are not substantially responsive to the requirement of the tender condition.
- c) Bid prices are substantially higher than that of the estimated cost/ available budget.

- d) Samples submitted do not meet the Quality Standards.
- e) Canvassing by the Bidder in any form including unsolicited letter and post-bid correction may invoke summarily rejection with forfeiture of EMD.
- f) Conditional bids shall be rejected.
- g) Submission of price bid along with the technical bid.

5.6. Right to Accept Any Bid and to Reject Any or All Bids

NIFT reserves the right to accept or reject any bid, and to annul the bidding process and reject all bids at any time prior to award of Contract, without assigning any reasons whatsoever and without thereby incurring any liability to the affected Bidder or Bidders or any obligation to inform the affected Bidder or Bidders on grounds of such action.

5.7. Nonconformities, Errors and Omissions

Once the technical bid is opened, no correspondence shall be entertained.

5.8. Contacting the NIFT

Any Bidder wishes to contact NIFT on any matter related to the bid during the interval of technical bid opening to the time of award of contract award, it should do so only in writing.

5.9. Bids of Debarred/ Blacklisted Firms

Bids of debarred / blacklisted firms will not be considered for evaluation.

5.10. Pre-Bid Meeting

A Pre Bid meeting to explain the exact scope of the work and to resolve queries of the participating agencies will be organized by NIFT on 02.11.2020 at 1100 Hours (IST) online or in the Boardroom of NIFT HO, Hauz Khas, New Delhi.

5.11. Technical Bid Opening

1. NIFT will open all the Bids received, in the presence of the Bidders or their representatives who choose to attend the bid opening at 1600 Hours (IST) on 17.11.2020 at National Institute of Fashion Technology (NIFT), Hauz Khas, New Delhi, India.
2. In the event of the specified date of the opening being declared a holiday by the Employer, the Bids will be opened at the appointed time and location on the next working day.
3. NIFT reserves the right to postpone or cancel a scheduled bid opening at any time prior to its opening. Information of the same will be displayed at NIFT website.

4. Opening of bids will be done through an online submission process.
5. The Bidder's representatives, who are present, shall mark attendance as per the mode specified by NIFT.
6. NIFT shall subsequently examine and evaluate the bids in accordance with the provision set out in the bid document.
7. The bids will be evaluated for qualifying criteria as mentioned in Clause 6.3. NIFT shall not be responsible for any postal delay in receipt of all documents and EMD. In case of non-receipt of these documents within the aforesaid period, the bid shall be treated as non-responsive.
8. The bids which qualify will be notified through email and on NIFT website.
9. It shall be the Bidder's responsibility to check the status of their Bid online regularly after the opening of bid till award of work.
10. The online price bid will be opened on the date which will be communicated to only those Bidders who are found to be technically qualified after evaluation of technical bids.

5.12. Place of Opening of Bid

Bid will be opened online or at the Board Room, National Institute of Fashion Technology, Head Office, Hauz Khas, New Delhi-16. The Bidders may depute their representatives, duly authorized in writing to attend the opening of Bids on the due date and time. This event will not be postponed due to the non-presence of representatives of any Bidder.

5.13. Time and Date for Opening of Technical Bids

Opening of Technical Bid date and time: 17.11.2020 at 1600 Hours (IST).

5.14. Opening of Price Bid

The online price bid shall be communicated to only those Bidders who are found to be technically qualified after evaluation of technical bids.

Price Bid in physical format shall not be accepted in any case. The price bid opened shall be of those firms / agencies who are qualified in the technical bid.

5.15. Period of Validity of Bids

Bids shall remain valid for the period of 180 days after the date of technical bid opening prescribed by NIFT. A bid valid for a shorter period shall be rejected by NIFT as non-responsive.

5.16. Issue of Letter of Intent (Lol)

Issue of Lol shall constitute the intention of tendering authority to enter into the contract with the Bidder. The Bidder shall within 07 days of issue of Lol give his unconditional acceptance to the terms and conditions of the tender in writing along with performance security in form of bank guarantee for an amount of 10% of contract value for a period of 13 months or completion of the project whichever is earlier.

5.17. Penalty for Use of Undue Influence

The Bidder undertakes that he has not given, offered or promised to give, directly or indirectly, any gift, consideration, reward, commission, fees, brokerage or inducement to any person in service of NIFT or otherwise in procuring the Contract or forbearing to do or for having done or forborne to do any act in relation to the obtaining or execution of the Contract or any other contract with the Government of India for showing or forbearing to show favour or disfavour to any person in relation to the Contract or any other contract with the Government of India. Any breach of the aforesaid undertaking by the Bidder or anyone employed by him or acting on his behalf (whether with or without the knowledge of the Bidder) or the commission of any offence by the Bidder or anyone employed by him or acting on his behalf, as defined in Chapter IX of the Indian Penal Code, 1860 or the Prevention of Corruption Act, 1986 or any other Act enacted for the prevention of corruption shall entitle NIFT to cancel the contract and all or any other contracts with the Bidder and recover from the Bidder the amount of any loss arising from such cancellation. A decision of the NIFT or his nominee to the effect that a breach of the undertaking had been committed shall be final and binding on the Bidder. Giving or offering of any gift, bribe or inducement or any attempt at any such act on behalf of the Bidder towards any officer/ employee of the NIFT or to any other person in a position to influence any officer/ employee of the NIFT for showing any favour in relation to this or any other contract, shall render the Bidder to such liability/ penalty as NIFT may deem proper, including but not limited to termination of the contract, imposition of penal damages, forfeiture of the Bank Guarantee and refund of the amounts paid by NIFT.

5.18. Access to Books of Accounts

In case it is found to the satisfaction of the NIFT that the Bidder has engaged an Agent or paid commission or influenced any person to obtain the contract as described in clause relating to Penalty for Use of Undue Influence (Clause 5.17), the Bidder, on a specific request of the NIFT, shall provide necessary information/ inspection of the relevant financial documents/information/Books of Accounts.

5.19. Non-disclosure of Contract Documents

Except with the written consent of the NIFT/ Bidder, no other party shall disclose the Contract or any provision, specification, plan, design, pattern, sample or information thereof to any third party.

5.20. Contract Amendments

No variation in or modification of the terms of the Contract shall be made.

5.21. Transfer and Sub-letting

The Bidder has no right to give, bargain, sell, assign or sublet or otherwise dispose of the Contract or any part thereof.

5.22. Withholding of Payment

In the event of the Bidder failure to submit the Bonds, Guarantees and Documents, supplying garments as specified in the Contract, the NIFT may, with its discretion, withhold / deduct/ adjust from the final payment due to the Bidder.

5.23. Liquidated Damages

If the Bidder fails to deliver the items or any consignment thereof within the period prescribed for delivery, NIFT shall be entitled to recover 1% of the value of the delayed supply with reference to the delivery dates given in the Purchase Order up to 7 days and thereafter at the rate of two percent (2%) of the value of the delayed supply for next 2 week of delay or part thereof and subsequent delay will be at four percent (4%) for every week of delay or part thereof.

Beyond that the work may be reassigned at the cost of the successful bidder.

5.24. Termination for Default

NIFT, without prejudice to any other remedy for breach of contract, by written notice of default sent to the Bidder, may terminate this Contract in whole or part,

- a) If the Bidder fails to deliver any or all the goods/ items within the time frame as specified in the Purchase Order or any extension thereof granted by the NIFT.
- b) If the Bidder fails to perform any obligation/s under the contract and
- c) If the Bidder, in either of the above circumstances, does not remedy its failure within a period of 15 days (or such longer period as the NIFT may authorize in writing) after receipt of the default notice from the NIFT.

Beyond that the work will be reassigned at the cost and risk of the successful Bidder.

5.25. Termination for Insolvency

NIFT may at any time terminate the Contract by giving written notice to the Bidder if the Bidder becomes bankrupt or otherwise insolvent. In this event, termination will be without compensation to the Bidder, provided that such termination will not prejudice or affect any right of action or remedy that has accrued or will accrue thereafter to the NIFT.

5.26. Force Majeure

Force Majeure shall mean any cause which is beyond the control of a Party or Parties or the Party invoking force majeure, including but not limited to the following: any law, decree, regulation, order, or request of any governmental authority, nationalization, expropriation, confiscation, requisition, riot, war, hostilities, public disturbance, act of the public enemy, strike, lock out, or other labor dispute, fire, flood, earthquake, storm, explosion, or Act of God. If either Party is prevented from or delayed in carrying out any provision of this Agreement by reason of Force Majeure the Party whose performance is so prevented or delayed, upon prompt written notice thereof to the other Party, shall be excused from such performance to the extent and during the period of such prevention or delay.

This clause shall not be available to a Party if such Party fails to use reasonable diligence to remedy the applicable situation described in above clause hereof with reasonable dispatch or if such applicable situation is caused by such Party.

The party for which it becomes impossible to meet obligations under the Contract due to Force Majeure conditions, is to notify in written form to the other party of the beginning and cessation of the above circumstances immediately, but in any case, not later than 10 (Ten) days from their commencement.

If the impossibility of complete or partial performance of an obligation lasts for more than 2 (two) months, either party here to reserves the right to terminate the Contract totally or partially upon giving prior written notice of 30 (thirty) days to the other party of the intention to terminate without any liability other than reimbursement on the terms provided in the contract. Force Majeure will be applicable throughout the contract period.

5.27. Settlement of Disputes through Arbitration

All disputes or differences arising out of or in connection with the Contract shall be settled through mutual consent between the parties. Any dispute, disagreement or question arising out of or relating to the Contract or relating to product or performance, which cannot be settled amicably, shall be resolved by arbitration as follows-

1. The case of arbitration may be referred to Director General of NIFT or a person appointed by him/her who will be the sole arbitrator and the arbitration proceeding shall be in accordance with the prevailing Arbitration and Conciliation Act, 1996 and Laws of India as amended or enacted from time to time being in force shall be deemed to apply to the arbitration proceeding under this clause.

2. The venue of the arbitration shall be New Delhi, India & the language of arbitration shall be English. The fee & other charges of Arbitrator shall be determined by the arbitrator in terms of the Act and shall be shared equally between the parties.
3. The arbitrator shall have powers to award only such remedy as is contemplated by this Agreement, including as appropriate, injunctive relief.
4. The parties shall not be entitled to any pendente-lite interest during arbitration proceedings.

5.28. Court Jurisdiction

Any dispute arising out to tender/ bid document / evaluation of bids / issue of Lol shall be subject to the jurisdiction of competent court at New Delhi only.

5.29. Notices

Any notices given by one party to the other pursuant to this Contract shall be sent to the other party through email and written notice. A notice shall be effective when delivered or on the notice's effective date, whichever is later.

5.30. Taxes and Duties

A Bidder shall be entirely responsible for all taxes, stamp duties, license fees, and other such levies imposed during the execution of the project.

5.31. Delivery

The delivery has to be as specified in Clause 1.4. However, NIFT reserves the right to get the supply immediately depending upon the urgent requirement. The name and mobile number of the nodal person, who can be contacted at any time, even beyond office hours and on holidays should be provided.

5.32. Penalty for Substandard / Inferior Quality

A penalty of 20% of Purchase Order shall be imposed on the Bidder for any substandard (inferior quality)/ incomplete supply along with cancellation of the work order. Further, the firm is also liable for blacklisting. In case of 20% or more product being substandard, it will be replaced free of cost within stipulated time which will be decided by NIFT.

If the selected Bidder does not supply the items within the stipulated period as may be indicated by NIFT, NIFT reserves the right to arrange the supply from another firm and the Bidder will have to reimburse the additional expenditure, if any, incurred by NIFT.

NIFT reserves the right to reject the delivery item in case that is not supplied as per quality/design colour of sample approved or found to be inferior quality and are not of requisite standards or of inferior quality, the same will have to be replaced otherwise performance bank guarantee will be forfeited and other action, as deemed fit, will be taken against the firm.

5.33. Change in Quantity

Quantity given in the financial bid is depending on the need of the Purchaser. However, NIFT reserves the right to vary the sizes mentioned in the quantity.

5.34. Award of Contract

The acceptance of tender and award of contract to one or more than one tenderer, if considered necessary, rests with NIFT. It shall not be obligatory on the part of NIFT to accept the lowest tenderer. NIFT would be at liberty to accept any tender, lowest or otherwise, in whole or in part and to reject any or all the tenders received, without assigning any reasons, and no explanation can be demanded of this by any tenderer in respect thereto.

6. PART VI - ELIGIBILITY CRITERIA FOR BID EVALUATION

The eligibility criteria for the Bidders to qualify for the Bid evaluation have been provided below.

6.1. Bid System & Evaluation

The selection of bidders will be based on two bid systems.

6.2. The Bid Evaluation Process

The bid evaluation process has two stages which consists of evaluation of following aspects:

Stage 1

1. Technical Bid - Clause 6.5 & 6.6

Stage 2

2. Price Bid - Clause 6.7 & 6.8

6.3. Technical Bid Evaluation

The Bidders are required to submit technical bid enclosing therewith photocopies of following documents (Documents in original should be produced for verification before signing of the agreement), failing which their bids will be summarily rejected and will not be considered any further.

However, it is informed that mere fulfilment of minimum eligibility criteria does not entitle the firm to demand that their financial bid will be evaluated.

Documents required for Technical Bid:

NO	ELIGIBILITY CRITERIA	DOCUMENTS REQUIRED TO SUBSTANTIATE THE SAME	Tick
A	Proof of Registration The Bidder should be an exclusively registered Agency /Company (Pvt./ Ltd. Company/ Public Ltd./ Partnership firm/ LLP/ Proprietorship firm) for not less than 5 years on the date of opening of the Technical Bid.	a. Registration certificate of the firm/ Partnership deed/ Certificate of incorporation etc. as applicable b. Article of Association & Memorandum of Association (If applicable)	

B	<p>Taxpayer Information The Bidder should have been in existence and should have been registered with the Tax Department.</p>	<p>a. Income Tax Registration (PAN No/ TAN No.) b. GSTIN Registration</p>	
C	<p>Turnover Certification & Income Tax Return The Bidder's annual gross turnover should not be less than Rs. 3 Crores at least for 3 years during the last five financial years</p>	<p>a. Copy of audited balance sheet and profit & loss account must also be attached for the F.Y. 2014-15, 2015-16, 2016-17, 2017-18 & 2018-2019. b. Income tax return along with income computation sheet for last 5 years (A.Y. 2015-16, 2016-17, 2017-18, 2018-19 & 2019-20).</p>	
D	<p>Bidders Experience Certificate</p> <p>1. Bidder should have its own apparel manufacturing set-up with a minimum average monthly sewing capacity of 60,000 knitted garments at average Standard Allowed Minutes of 10 minutes or manufacturing similar styles (Tee and legging) as required by NIFT. (Job work or sub-contract is NOT Allowed)</p> <p>2. Basic Quality Management Systems in place with AQL 1.5 to AQL 4.0</p> <p>3. Social and Technical Compliances norms should be followed</p>	<p>1. Copies of the supply order should be submitted duly signed by the Bidder in order to confirm the average monthly capacity in last 3 years</p> <p>2. Submit 3 Final QC Reports of different orders done in the recent past.</p> <p>3. The bidder should be socially compliant and should have valid certifications. Any current compliance certificate should be submitted.</p>	

E	Earnest Money Deposit	Earnest Money Deposit of Rs. 9 lakhs in the form of Demand Draft/ Bank Guarantee. Annexure – II. (Not exempted in any case except those Bidders exempted from EMD, submit the certificate issued by the concerned department i.e. NSIC, MSME, SSI etc.)	
F	Tender Acceptance Letter	To be given on the company's letterhead. Annexure IV duly signed by authorized signatory.	
G	Price Bid Ref Clause 6.7 & 6.8	To be filled Online only in the specified format as per Annexure III. PS: Don't enclose the Price Bid along with the Technical Bid, if found along with the technical bid the bidder will be disqualified.	
H	Samples The bidders to submit the Proto Samples (One complete set) with the actual or nearest possible fabrics and trims without logo. The sample submitted should be for male and female as per the measurements specifications of any one size, preferably Medium	List of number of quantity of samples provided. Samples have to be submitted to The Purchase Officer, National Institute of Fashion Technology, NIFT Campus, Near Gulmohar Park, Hauz Khas, New Delhi-110016, Mobile No. +91 9810136563 Phone No. +91 11 26542017/2176, email - purchase.ho@nift.ac.	
All documents to be submitted should be self-attested by the Bidder. The Bidder who will be technically qualified in documents as well as in the test report only will be qualified for opening Price Bid.			

6.4. Technical Bid Evaluation

1. Bidders fulfilling the Technical Bid criteria shall be shortlisted.
2. NIFT will examine the Bids to determine whether they are complete, whether any computational errors have been made, whether required sureties have been furnished, whether the documents have been properly signed & stamped and whether the bids are generally in order.

3. The bids will be scrutinized to determine whether they are complete and meet the essential and important requirements, conditions etc. as prescribed in the bid document. The bids, which do not meet the basic requirements, are liable to be treated as non – responsive and will be rejected.
4. The following are some of the important aspects, for which a bid shall be declared non – responsive during the evaluation and will be rejected:
 - a) EMD not deposited
 - b) Bid is unsigned or undertaking provided
 - c) Bid validity is shorter than the required period
 - d) Poor/ unsatisfactory past performance
 - e) Incomplete information
 - f) Lack of required documents
 - g) Failure in arrangement of documents
 - h) Non submission of samples
5. Technical Bid will be evaluated by the Tender Evaluation Committee constituted for the purpose. An evaluation criteria is enclosed for ready reference Clause 6.3. The committee will record in detail the criteria adopted for acceptance or rejection of the technical proposals.
6. The Tender Evaluation Committee will also examine the samples submitted by the bidder.
7. The bid committee will evaluate the price bids of only those Bidders who qualify the technical bid. Price Bid will be evaluated for completeness, justification for each item, appropriateness, rational and other criteria as considered by the evaluating committee and enclosed for ready reference in clause 6.8.

6.5. Price Bid

The rates/ prices should be quoted in Indian Rupees only in words as well as figures. Taxes, if any, should be indicated separately. Only one price should be quoted for each category and if more than one price is quoted under different headings the rate quoted by the Bidder in the first heading only will be considered for evaluation.

Rates/ prices should be valid for 13 months from the date of filling the price bid. Rates/ prices shall not be increased during the entire period of the contract i.e. 13 months and shall not be subject to variation on any account. A bid submitted with an adjustable price quotation will be treated as non responsive and will be rejected.

Prices should be quoted on a FoB basis with free of cost delivery at NIFT Campuses as specified in Clause 1.4. The Bidder should quote rates as per specifications mentioned in the tech packs only as described in Clause 2.2.1.

Price Bid Submission Online Form

Heads	Quantity	Rate per piece (in Rs)	Total Cost for the quantity (in Rs)	Total GST (in Rs)	Total to be quoted inclusive of taxes/ duties/ other costs (in Rs)
	A	B	C=A*B	D	E= C+D
Women's Vest	15000				
Women's Leggings	15000				
Men's Vest	15000				
Men's Cycling Shorts	15000				
Unisex Scan cap	30000				
Unisex Face mask	30000				
Women's Bra	5000				
Carry Bag	30000				
Total Amount (in figure)					
Total Amount (in words)					

In case of difference in quoted price in figures and words, price quoted in words will prevail.
For release of payment refer to Clause 4.1.

6.6. Price Bid Evaluation

1. The date and time of opening the price bid will be intimated to technically qualified Bidders through email.
2. Likewise, following the evaluation of technical Bid, NIFT shall examine the Online Price Bid as per Annexure III.
3. If any of the information is missing, the offer shall be rejected.

ANNEXURE I - Technical Bid

1.	Name of the Bidder	:
2.	Name of Proprietor/Partners/Directors of the firm/agency:	
3.	Name of the authorized person (Who signs on the bid document):	
4.	Address of the Bidder	:
5.	Phone No	:
6.	Email- address	:
7.	Mobile No.	:
8.	Whatsapp no.	:
9.	Banking Details of the bidder	:

Eligibility Criteria for Selection: -

NO	ELIGIBILITY CRITERIA	DOCUMENTS REQUIRED TO SUBSTANTIATE THE SAME	Proof Required
A	Proof of Registration The Bidder should be an exclusively registered Agency /Company (Pvt./ Ltd. Company/ Public Ltd./ Partnership firm/ LLP/ Proprietorship firm) for not less than 5 years on the date of opening of the Technical Bid.	a. Registration certificate of the firm/ Partnership deed/ Certificate of incorporation etc. as applicable b. Article of Association & Memorandum of Association (If applicable)	Scanned copy of the document submitted online
B	Taxpayer Information The Bidder should have been in existence and should have been registered with the Tax Department.	a. Income Tax Registration (PAN No/ TAN No.) b. GSTIN Registration	Scanned copy of the document submitted online
C	Turnover Certification & Income Tax Return The Bidder's annual gross turnover should not be less than Rs. 3 Crores at least for 3 years during the last five financial years	a. Copy of audited balance sheet and profit & loss account must also be attached for the F.Y. 2014-15, 2015-16, 2016-17, 2017-18 & 2018-2019. b. Income tax return along with income computation sheet for last 5 years (A.Y. 2015-16, 2016-17, 2017-18, 2018-19 & 2019-20).	Scanned copy of the document submitted online
D	Bidders Experience Certificate		Scanned copy of the

	<p>1. Bidder should have its own apparel manufacturing set-up with a minimum average monthly sewing capacity of 60,000 knitted garments at average Standard Allowed Minutes of 10 minutes or manufacturing similar styles (Tee and legging) as required by NIFT. (Job work or sub-contract is NOT Allowed)</p> <p>2. Basic Quality Management Systems in place with AQL 1.5 to AQL 4.0</p> <p>3. Social and Technical Compliances norms should be followed</p>	<p>1. Copies of the supply order should be submitted duly signed by the Bidder in order to confirm the average monthly capacity in last 3 years</p> <p>2. Submit 3 Final QC Reports of different orders done in the recent past.</p> <p>3. The bidder should be socially compliant and should have valid certifications. Any current compliance certificate should be submitted.</p>	document submitted online
E	Earnest Money Deposit	Earnest Money Deposit of Rs. 9 lakhs in the form of Demand Draft/ Bank Guarantee. Annexure – II. (Not exempted in any case except those Bidders exempted from EMD, submit the certificate issued by the concerned department i.e. NSIC, MSME, SSI etc.)	Scanned copy of the document submitted online and original bank guarantee should reach by 17.11.2020 at 14:00 Hours
F	Tender Acceptance Letter	To be given on the company's letterhead. Annexure IV duly signed by authorized signatory.	Scanned copy of the document submitted online
G	Price Bid Ref Clause 6.7 & 6.8	To be filled Online only in the specified format as per Annexure III. PS: Don't enclose the Price Bid along with the Technical Bid, if found along	

		with the technical bid the bidder will be disqualified.	
H	<p>Samples</p> <p>The bidders to submit the Proto Samples (One complete set) with the actual or nearest possible fabrics and trims without logo. The sample submitted should be for male and female as per the measurements specifications of any one size, preferably Medium</p>	<p>List of number of quantity of samples provided.</p> <p>Samples have to be submitted to The Purchase Officer, National Institute of Fashion Technology, NIFT Campus, Near Gulmohar Park, Hauz Khas, New Delhi-110016, Mobile No. +91 9810136563 Phone No. +91 11 26542017/2176, email - purchase.ho@nift.ac.</p>	<p>Scanned copy of the document submitted online and original samples should reach by 17.11.2020 at 14:00 Hours</p>
	<p>All documents to be submitted should be self-attested by the Bidder.</p> <p>The Bidder who will be technically qualified in documents as well as in the test report only will be qualified for opening Price Bid.</p>		

ANNEXURE II - Details of Earnest Money Deposit**Details of Earnest Money Deposit (Bid No. 1351(27)/NIFT/Pur-HO/INDIAsize Project/Scan Suit /2020)**

S. No.	Title	Details
1	Name and Address of the Company	
EMD		
2	Details of Interest free Earnest Money Deposit (EMD). The demand draft of Earnest Money Deposit (EMD) has to be physical and encashable No.	Amount: TT/NEFT/RTGS Details/Demand Draft No.: Date: Bank Name:

Date :

SIGNATURE OF AUTHORISED REPRESENTATIVE

Place :

NAME

COMPANY SEAL

(Please attach Authorization letter for signatory)

ANNEXURE III - Price Bid

NIFT Head Office GSTIN. - 07AAATN2067J1ZI

Heads	Quantity	Rate per piece (in Rs)	Total Cost for the quantity (in Rs)	Total GST (in Rs)	Total to be quoted inclusive of taxes/ duties/ other costs (in Rs)
	A	B	C=A*B	D	E= C+D
Women's Vest	15000				
Women's Leggings	15000				
Men's Vest	15000				
Men's Cycling Shorts	15000				
Unisex Scan cap	30000				
Unisex Face mask	30000				
Women's Bra	5000				
Carry Bag	30000				
Total Amount (in figure)					
Total Amount (in words)					

In case of difference in quoted price in figures and words, price quoted in words will prevail.

ANNEXURE IV – Tender Acceptance Letter

(To be given on Company's Letter Head)

Date:

Sub: Acceptance of Terms & Conditions of Tender

Tender Bid No. 1351(27)/NIFT/Pur-HO/INDIAsize Project/Scan Suit/2020

Name of Work: Supplier of Scan Suits

1. I/ We have downloaded/obtained the tender document(s) for the above mentioned 'Tender' from the web site(s) namely:-<https://nifttenders.eproc.in>
2. I/We hereby certify that I/We have read entire terms and conditions of the tender documents from Page No. 01 to 53 (including all documents like annexure), schedule(s), etc.), which form part of the Tender and I/We shall abide hereby the terms / conditions / clauses contained therein.
3. The corrigendum(s) issued from time to time by your organization too have also been taken into consideration, while submitting this acceptance letter.
4. I/We hereby unconditionally accept the tender conditions of above mentioned tender document(s) / corrigendum(s) in totality/entirely.
5. I/We do hereby declare that our Firm has not been blacklisted/ debarred by any Government Department/Public sector undertaking.
6. I/We do hereby declare that our firm has not been part of a cartel with other vendors and will quote competitive rates in the bids.
7. I / We certify that all information furnished by me/ us/ our firm is true & correct and in the event that the information is found to be incorrect/untrue or found violated, then your organization shall without giving any notice or reason therefor, summarily reject the bid, without prejudice to any other rights or remedy including the forfeiture of the full said earnest money deposit absolutely. We shall not have any claim/ right against organization in satisfaction of this condition.

Yours faithfully
(Signature of the Bidder, with Official Seal)

Name of the Authorized Signatory:

Designation:

Contact details (including E-mail):

Date:

Place:

National Institute of Fashion Technology

Project- INDIAsize

Clarification given in Pre-bid meeting held on 02.11.2020 related to Bid No. 1351(27)/NIFT/Pur-HO/INDIAsize Project/ Scan Suit/2020

Clarification on material specification of the tender Clause2.2.1

Sr. No.	Comment	Mentioned in Tender	To be Read as
1	Material for Top & Cap <ul style="list-style-type: none"> • Women's vest Page 10 • Men's Vest Page 14 • Cap Page 18 	Fabric Type: Knits 1x1 Rib Fabric Composition: 95% Cotton 5% Spandex GSM: 190-220	Fabric Type: Knits 1x1 Rib (with Yarn Count 40's or finer) Fabric Composition: 95% Cotton 5% Spandex GSM: 190-220
2	Material for Bottom <ul style="list-style-type: none"> • Women's legging Page 12 • Men's shorts Page 16 	Fabric Type: Single Jersey Fabric Composition: 95% Cotton 5% Spandex GSM: 200-220	Fabric Type: Single Jersey (with Yarn Count 30's or finer) Fabric Composition: 95% Cotton 5% Spandex GSM: 190-220
2	Material for Mask <ul style="list-style-type: none"> • Mask Page 20-21 	Fabric Type: Single Jersey Fabric Composition: 95% Cotton 5% Spandex GSM: 200-220	Fabric Type: Single Jersey (with Yarn Count 30's or finer) Fabric Composition: 100% cotton or 97% Cotton 3% Spandex GSM: 90-100 Mask page 20-21 Alternative to TECH PACK FACE MASK , any other mask with INDIAsize logo (as mentioned in the specification sheet) can be provided. The filter of the mask should be compliant with at least Level 1 ASTM 2101/ EN 14683 or alternative equivalent standard which is certified by accredited agency preferably government. Certification to be provided along with the sample of the mask while submitting with technical bid.

Query	Clarification
MSME deposit PBG in parts as per delivery.	PBG has to be provided in one go
Is Tender fees exempted for MSME.	NIFT is not charging any tender fee from any bidders. The fee is being charged by M/s. C1 India Pvt. Ltd. third party who will float the tender on behalf of NIFT and has to be paid.